

USB-CAM - Series

**USB-CAM-003H, USB-CAM-103H
USB-CAM-004H, USB-CAM-104H
USB-CAM-051H, USB-CAM-151H
USB-CAM-052H, USB-CAM-152H**



Manual

Edition January 2016

In this manual are descriptions for copyrighted products that are not explicitly indicated as such. The absence of the trademark (™) and copyright (©) symbols does not imply that a product is not protected. Additionally, registered patents and trademarks are similarly not expressly indicated in this manual.

The information in this document has been carefully checked and is believed to be entirely reliable. However, PHYTEC Messtechnik GmbH assumes no responsibility for any inaccuracies. PHYTEC Messtechnik GmbH neither gives any guarantee nor accepts any liability whatsoever for consequential damages resulting from the use of this manual or its associated product. PHYTEC Messtechnik GmbH reserves the right to alter the information contained herein without prior notification and accepts no responsibility for any damages which might result.

Additionally, PHYTEC Messtechnik GmbH offers no guarantee nor accepts any liability for damages arising from the improper usage or improper installation of the hardware or software. PHYTEC Messtechnik GmbH further reserves the right to alter the layout and/or design of the hardware without prior notification and accepts no liability for doing so.

© Copyright 2016 PHYTEC Messtechnik GmbH, D-55129 Mainz.

Rights - including those of translation, reprint, broadcast, photomechanical or similar reproduction and storage or processing in computer systems, in whole or in part - are reserved. No reproduction may occur without the express written consent from PHYTEC Messtechnik GmbH.

For further information:

	EUROPE	NORTH AMERICA
Address:	PHYTEC Technologie Holding AG Robert-Koch-Str. 39 D-55129 Mainz GERMANY	PHYTEC America LLC 203 Parfitt Way SW, Suite G100 Bainbridge Island, WA 98110 USA
Ordering Information:	+49 (6131) 9221-30 order@phytec.de	1 (800) 278-9913 sales@phytec.com
Technical Support:	+49 (6131) 9221-31 support@phytec.de	1 (800) 278-9913 support@phytec.com
Fax:	+49 (6131) 9221-33	1 (206) 780-9135
Web Site:	http://www.phytec.de	http://www.phytec.com

2st Edition January 2016

Table of Contents

1	Delivery Contents	4
1.1	Accessories	4
1.2	What you Need for the Initial Start-Up.....	5
1.3	Features of the USB-CAM series.....	6
1.4	Important Notes.....	7
1.5	Declaration of Conformity	8
1.6	Overview of Connectors and Settings.....	9
1.7.1	Connectors.....	9
1.6.2	Settings.....	10
2	First Steps	11
2.1	Hardware-Installation on a PC	11
2.1.1	The USB Connection	11
2.2	Installation of the Driver Software.....	14
2.3	Mounting a Lens.....	20
2.4	Installation of the Demo Program	23
2.5	Starting Up the Camera with the Demo Program	26
2.5.1	The First Live Image	26
2.5.2	Select resolution	28
2.5.3	Problem Solving.....	30
2.5.4	Adjusting Camera Settings.....	31
3	The Camera in Detail	37
3.1	Camera Connections	37
3.1.1	USB Interface.....	37
3.1.2	External Triggering, FCAM-111H /112H Only	37
3.2	Connecting the Lens.....	41
3.3	Mechanical Attachment.....	45
3.4	How to Maximize Image Quality.....	47
3.4.1	Lens	47
3.4.2	Lighting	47
3.4.3	Camera Setup	53
4	The Software Concept	58
4.1	Layers Standards of the USB-CAM Series.....	58
4.2	Accessing the Camera Driver.....	60
4.3	Working with the Filter Graph Editor	61
4.3.1	How to Get the Filter Graph Editor	61
4.3.2	Working with the Filter Graph Editor.....	61
4.3.3	How the Camera Appears in the Filter Graph Editor....	62
5	Technical Data	64
5.1	frame rates and sensitivity.....	66
6	Dimensions	67

Table of Figures

Figure 1:	USB Connecting Cable	4
Figure 2:	Rear view without trigger	9
Figure 3:	Rear view with trigger	9
Figure 4:	USB-Connector (PC)	11
Figure 5:	USB-Connector (Camera).....	11
Figure 6:	USB-Logo	12
Figure 7:	USB Connecting Cable Type-A – Type Mini-B	12
Figure 8:	Title Menu of the „Vision Tools“ CD	15
Figure 9:	Installation Menu for the USB Camera	16
Figure 10:	Driver Installation, Step 1	17
Figure 11:	Driver Installation, Step 2.....	18
Figure 12:	Driver Installation, Compatibility Warning.....	18
Figure 13:	Driver Installation, Step 3	19
Figure 14:	Lens Assembly (C-Mount)	20
Figure 15:	Flange Back Distances and Mounting of C-Mount (Top) / CS-Mount (Bottom) Lenses	21
Figure 16:	Title Menu of the, Vision Tools‘ CD	24
Figure 17:	Installation Menu for the USB Cameras.....	24
Figure 18:	Demo Installation, Step 1.....	25
Figure 19:	Installation Completed, Step 4.....	25
Figure 20:	The Program „PHYTEC Vision Demo“	26
Figure 21:	PHYTEC Vision Demo – Select Device	27
Figure 22:	PHYTEC Vision Demo – Live View Function Activated.....	27
Figure 23:	resolutions W-VGA-Models	29
Figure 24:	resolutions 5 Megapixel-Models.....	30
Figure 25:	Camera Setting „Device Settings“	32
Figure 26:	Camera Setting „Properties Color“	33
Figure 27:	Camera Setting „Properties Exposure“	34
Figure 28:	Camera Setting „Properties Special“	34

Figure 29: Further: Camera Settings „Partial Scan“	35
Figure 30: Further possible Settings of the PHYTEC-Vision-Demo	36
Figure 31: Connections USB-CAM	38
Figure 32: Trigger-Connector	38
Figure 33: Waveform Trigger	39
Figure 34: Digital Output	40
Figure 35: virtual sensor sizes (5M-pixel models)	42
Figure 36: virtual sensor size at different resolutions	42
Figure 37: Mounting Plate	45
Figure 38: Attachment of the Mounting Plate	46
Figure 39: Mounting Options of the USB-CAM	46
Figure 40: PHYTEC Ring Light Order No.: VZ-001-x, VZ-002-x	48
Figure 41: Light-Field- (Left) and Dark-Field-Lighting (Right)	49
Figure 42: The Shadow Projection	50
Figure 43: The Structured Light	51
Figure 44: The Silhouette Projection	52
Figure 45: Transillumination	53
Figure 46: Dimensions without trigger	67
Figure 47: Dimensions with trigger	68

1 Delivery Contents

The standard scope of supply includes the following components:

- the camera
- a C/CS-mount adapter
- a tripod adapter (bolted together with the camera)
- the **software**-CD SO-221
- this manual

1.1 Accessories

For the operation of the camera you normally need some additional components.

You can obtain following material designed to be compatible with the camera from PHYTEC:



Figure 1: USB Connecting Cable

- USB Connecting Cable, 1.5 m
Order number WK184

Hint:

- Please note that the full data rate is specified for a cable length of up to 5 m.
- Video lenses:
In our product range we keep a variety of high-quality lenses for several purposes. We will gladly assist you in choosing an adequate lens.
- Additional accessories:
Depending on your application you may need further components. We are happy to assist you in case any questions should occur.

1.2 What you Need for the Initial Start-Up

For the initial basic start-up you usually need only the USB-CAM and a PC with an USB 2.0 Interface.

For completeness, here are all the components listed:

- A C- or CS-Mount lens. Please note however that the high quality of digital cameras should not be reduced by using lenses of low quality (*see section 3.4, "How to Maximize Image Quality"*). PHYTEC provides a wide range of compatible high-quality lenses.
- A PHYTEC USB camera.
- A cable for the connection between camera and USB bus. This will usually be the USB interface (host controller) of your computer. PHYTEC provides therefore a cable. You can use any other cable alternatively if they comply with the USB 2.0 standard
- A computer (PC, laptop) that meets the following requirements

Caution!

The host computer has to meet following requirements:

- USB 2.0 interface, compatible with the standards USB 2.0 Standard. Current capacity up to 500mA (standard). If using a USB hub you must usually use an external power supply for the hub, otherwise it can happen that the USB port can only be loaded with about 100mA.
- processor: Pentium IV, 2GHz, 512 MB RAM or higher
- Graphics adaptor with 24 or 32-bit colour depth
- Operating system: Windows XP SP3, VISTA, 7, 8, 10 (32 / 64 Bit)
- DirectX 9.0c or higher

1.3 Features of the USB-CAM series

Resolution	744 x 480 / 640 x 480 / 320 x 240			
Model	USB-CAM-003H USB-CAM-103H		USB-CAM-004H USB-CAM-104H	
color / monochrom	monochrom		color	
Sensor size	1/3" CMOS			
Color format	Y8		RGB32, RGGB (Raw)	
Interface	USB 2.0 High Speed (USB Mini-B)			
Feature (optional)	-	ext. Trigger, Digital- Output	-	ext. Trigger, Digital- Output
fps	Up to 150 fps			
Order number	AK087	AK089	AK088	AK090

Resolution	2592 x 1944 (5 MPix), 2048 x 1536 (3,1MPix), 1600 x 1200 (2MPix), 1280 x 960 (1,2MPix) 1024 x 768 (0,8MPix), 640 x 480 (VGA)			
Model	USB-CAM- 051H	USB-CAM- 151H	USB-CAM- 052H	USB-CAM- 152H
color / monochrom	monochrom		color	
Sensor size	1/2,5" CMOS			
Color format	Y8		RGB32, RGGB (Raw)	
Interface	USB 2.0 High Speed (USB Mini-B)			
Feature (optional)	-	ext. Trigger, Digital- Output	-	ext. Trigger, Digital- Output
fps	Up to 52 fps			
Order number	AK091	AK093	AK092	AK094

- WDM Stream Class driver included
- PHYTEC-SDK included
- connection for C-/CS-Mount lenses (lens not included)

Note:

- Find the detailed technical data in *section 5*.

1.4 Important Notes

- We hereby expressly note that, according to the product liability law, we cannot be made responsible for damages caused by our devices if they have been used or repaired inappropriately or if, in case of a component replacement resp. system construction, other parts than our original components or components approved by us have been used, and especially if the operating instructions were not correctly followed.
- Handle the camera with care. Avoid hard shocks, concussions, etc. The camera can be damaged by incorrect handling and wrong storage.
- Do not try to disassemble the camera. To avoid electric shocks, do not remove neither screws nor the case. There are no components in the camera that need user maintenance. Maintenance work may only be carried out by qualified maintenance personnel.
- Never use strong or abrasive detergents (e. g. alcohol, benzene or turpentine) to clean the case of the camera. Wipe the case with a soft cloth slightly moistened with a neutral cleanser.
- Never expose the camera to humidity, dust or dirt. This camera is intended for indoor use only. Humidity can damage the camera and cause the risk of electric shock.
- Never point the camera towards the sun or very bright objects. Otherwise this may lead to blooming and smear.
- Keep the camera shut or mount a lens to avoid getting dust on the CMOS chip.

- Clean the CCD front panel carefully. Never use strong or abrasive detergents for the cleaning of the CCD front panel.
- Only use the original cable and power supply intended for the camera. The warranty expires if other cables or power supplies are used.

1.5 Declaration of Conformity

The cameras meet the EC directive 2004/108/EG for a digital device of class B. They have been tested and thus conform to EN 55016-2-3:2006, EN 61000-6-3:2007, EN 61000-4-2:2009, EN 61000-4-3:2006 and EN 61000-6-2:2005.

To conform to EU standards, shielded cables have to be used to connect other devices to the camera. The cameras have been tested in a typical environment complying with class B. It is therefore assumed that the cameras will also be functioning in other environments complying with class B.

1.6 Overview of Connectors and Settings

1.7.1 Connectors

Usually you only need the USB bus for connecting the camera. That bus transmits the video data, the control data and the supply voltage for the camera.

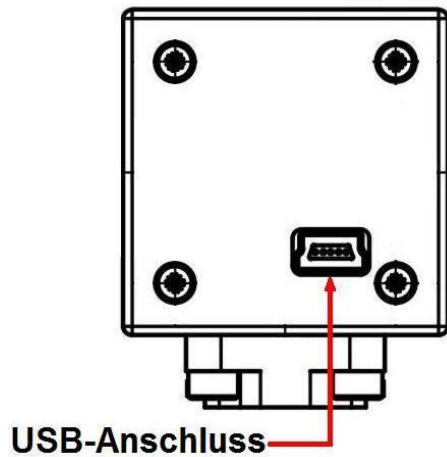

Figure 2: Rear view without trigger

The USB-CAM-103H, 104H, 151H and 152H are equipped with a BNC socket for the connection to an external trigger signal.

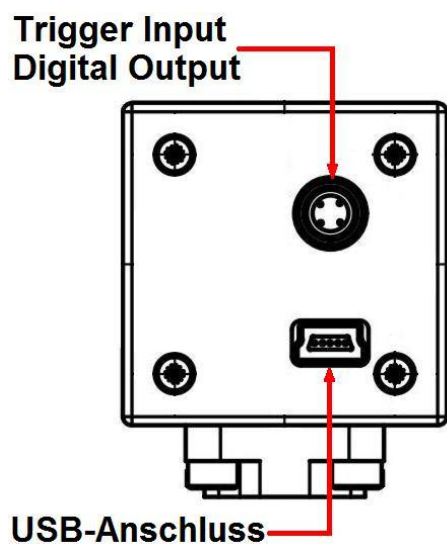

Figure 3: Rear view with trigger

1.6.2 Settings

All parameters of the camera are adjustable via the USB bus. The camera is delivered with a sample application (requires Windows XP or higher and DirectX 9.0c or higher), that allows for the acquisition of images and streams of images and the adjustment of the basic parameters (*see section 2.5*)

It is, of course, possible to adjust the camera parameters independently from this program. For this purpose, PHYTEC offers a WDM Stream Class driver (*see section 4*) which allows the parameters to be set with every image processing software compatible to DirectX 9.0c or higher.

Alternatively the PHYTEC-SDK (DirectX wrapper) can be used. It allows for a very convenient access to all features of the USB-CAMs without the programmer having to become acquainted with the complexity of DirectX. The SDK includes connections to several programming interfaces:

- **.NET Komponenten:** for MS Visual Basic .NET and C# .NET
- **ActiveX Control:** for Microsoft Visual Basic 2005 and 2008
- **C++ Class Library:** Microsoft Visual C++ 7.1, 8 and 9.

For each of these interfaces the SDK provides all binaries, headers and libraries needed, a detailed help as well as sample projects and demo programs with source codes.

You will find an overview dealing with the programming in *section 4 „The Software Concept“*. The complete specifications for the features you will find in the help files dealing with the respective programming environments on the *„Vision-Tools“-CD, SO-221*.

An outline of standardised dialogues is available in *section 2.5.4*.

2 First Steps

This chapter explains how to connect the USB camera to your computer and how to install the software needed for the first image acquisitions.

Section 2.1: Installation of the camera on a standard PC

Section 2.2: describes the installation of the software for all hardware variants.

2.1 Hardware-Installation on a PC

2.1.1 The USB Connection

Check first if your computer is already equipped with a USB interface.

These sockets are known as type A USB connector (*Figure 4*).

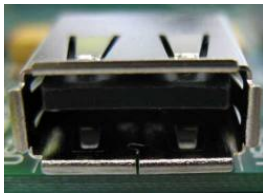

Figure 4: USB-Connector (PC)

On the camera side is an USB socket of the type MINI-B (*Figure 5*).



Figure 5: USB-Connector (Camera)

You will be able to identify this socket by the USB logo (*Figure 6*).



Figure 6: USB-Logo

All signals and the supply voltage necessary for operating the camera are usually available on this socket.

Therefore only one single cable is necessary for the camera (*Figure 7*).



Figure 7: USB Connecting Cable Type-A – Type Mini-B

Depending on the desired length of the cable, you can use one of these USB cables for the connection:

- USB connecting cable, 1.5 m
Order number WK184

Hints:

- In case your PC should not have a USB 2.0 interface, you would first have to install a USB 2.0 interface card to be able to use the camera.
- Please note that the full data rate is specified only for a cable length of up to 5 m.

The USB interface is „hot-plug“-capable. This means that you can connect and disconnect the camera without having to shut down your computer. Please mind however to close all programs that access the camera to avoid data loss.

To put the camera into operation, simply plug one end of the USB cable (Type Mini-B) into the socket on the back of the camera and the other end into the USB-Connector on your PC.

Further connections are not required.

Caution!

You will have to install the respective driver software on your PC prior to the initial operation. Without the installation of the driver, the camera will not function at all or merely in a limited way.

Please read *section 2.2* how to install the driver.

2.2 Installation of the Driver Software

The appropriate software device driver has to be installed so that the camera can be addressed by the application software.

This device can be found on the CD that is included with the camera. You can also download driver software updates from the PHYTEC website (www.phytec.de).

Caution!

Check first to see if your computer meets the following system requirements for operating the camera:

- USB 2.0 interface, compatible with the standards USB 2.0 Standard. Current capacity up to 500mA (standard). If using a USB hub you must usually use an external power supply for the hub, otherwise it can happen that the USB port can only be loaded with about 100mA.
- processor: Pentium IV, 2GHz, 512 MB RAM or higher
- Graphics adaptor with 24 or 32-bit colour depth
- Operating system: Windows XP SP3, VISTA, 7, 8, 10 (32 / 64 Bit)
- DirectX 9.0c or higher

Make sure that your computer meets the hardware requirements and is equipped with this software.

To install the driver software for the USB camera, proceed in the following manner:

Caution!

The DirectX driver must be installed prior to installation of the driver software for the USB camera. Otherwise not all driver functions will be supported and/or the system may crash.

- Connect the camera to your computer. To install the driver the camera must be ready for operation. Follow the instructions in the previous sections for this.

- Insert the CD SO-221 in your computer's CD-ROM drive.
- The CD should start automatically, bringing up the title menu shown in *Figure 8*.
If the CD doesn't start automatically: open the content folder of the CD (from your desktop or using Windows Explorer) and double click on *SO-221.exe*.

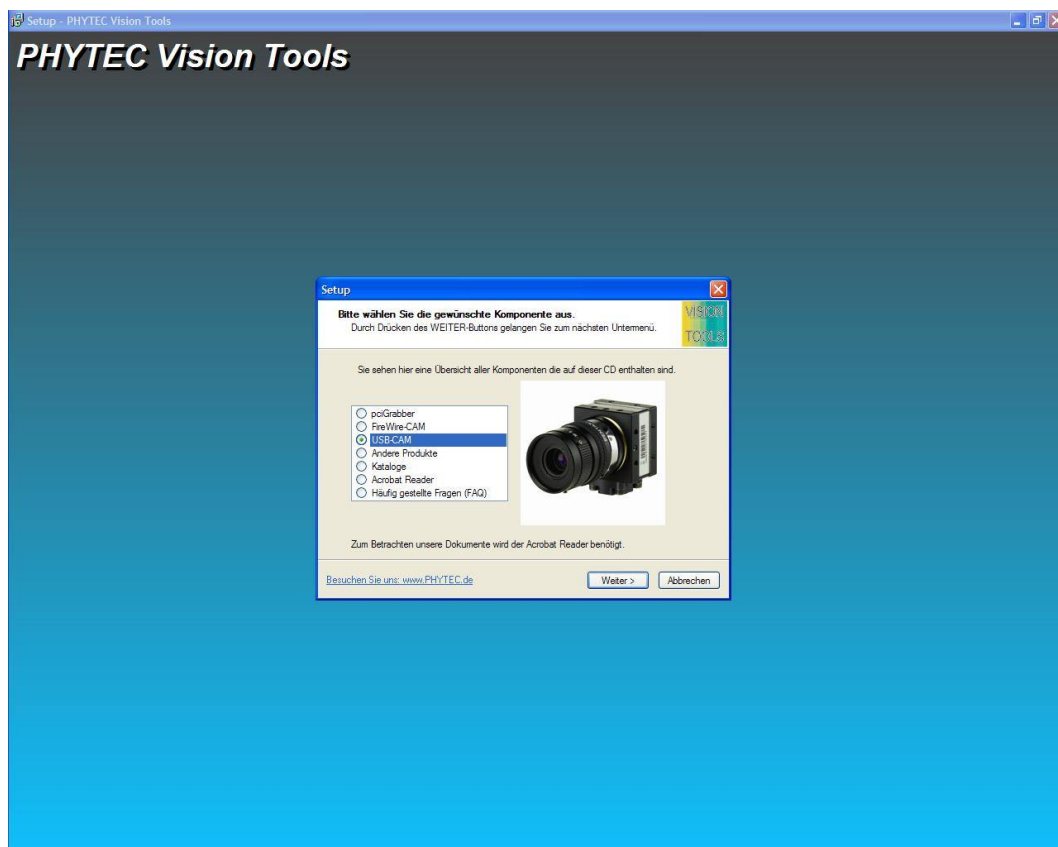

Figure 8: Title Menu of the „Vision Tools“ CD

- Click on *USB-CAM*. You will be taken to the installation menu for the PHYTEC USB Camera. Install 32Bit Driver (*Figure 9*) and click on *Next*. To install the 64Bit driver please select the ‘Install 64Bit Driver’.

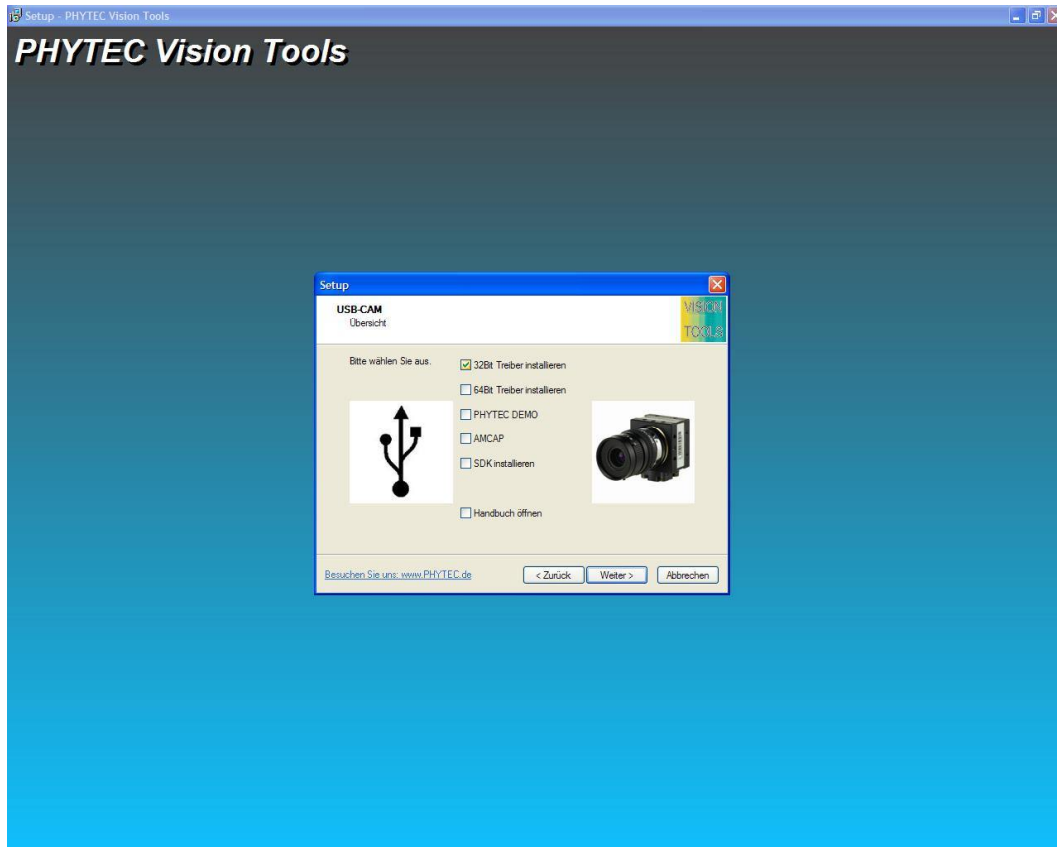

Figure 9: Installation Menu for the USB Camera

- The installation program of the USB Camera's software driver will appear, *Figure 10*:



Figure 10: Driver Installation, Step 1

- Select the camera model that is connected to the USB interface. (This model should already be selected.)
If no selection appears, check to see if the camera is connected correctly and ready for operation. This is required before the driver can be installed. Click on „Next“ or “Weiter”.
- The driver is now installed (*Figure 11*)
In some cases a software compatibility warning will appear (*Figure 12*). Click on „Continue Installation“ or “Installation fortsetzen”.

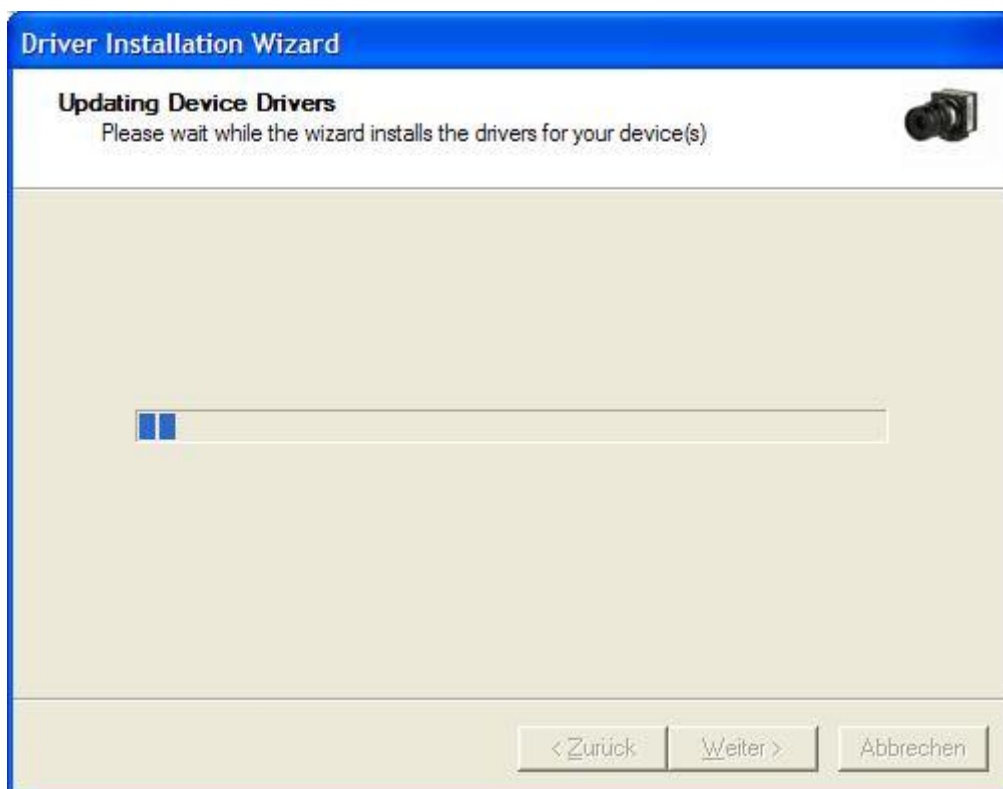

Figure 11: Driver Installation, Step 2



Figure 12: Driver Installation, Compatibility Warning

- At the end of the installation you will receive a message (Figure 13). Click on „Finish“ or “Fertig stellen”.



Figure 13: Driver Installation, Step 3

- Now remove the USB cable from the camera and wait a moment, than reconnect the cable.
- The driver installation is now complete.

Note:

- If you would like to run several different type cameras of the PHYTEC USB series on the same computer, you have to perform the installation procedure for each camera.
- After the installation procedure has been performed on a computer, you can connect and disconnect the camera as often as you like. The USB interface automatically activates the driver.

In the next two sections, you will be shown how to mount a lens on your camera and then how to display your first live picture on your screen.

2.3 Mounting a Lens

At first glance mounting a lens seems simple. However, when dealing with high-quality digital cameras, the selection of an appropriate lens and its correct mounting can play a decisive role in the image quality.

There are a few recommendations for selecting an appropriate lens in *section 3.2*. The following paragraphs provide instructions on the connection of a lens. The USB-CAM series works with C- resp. CS-Mount lenses.

The difference between these two lens types is marginal: If you want to connect a C-Mount lens, you need to attach a CS/C-adaptor-ring between the lens and the camera. With CS-Mount lenses, this ring cannot be used.

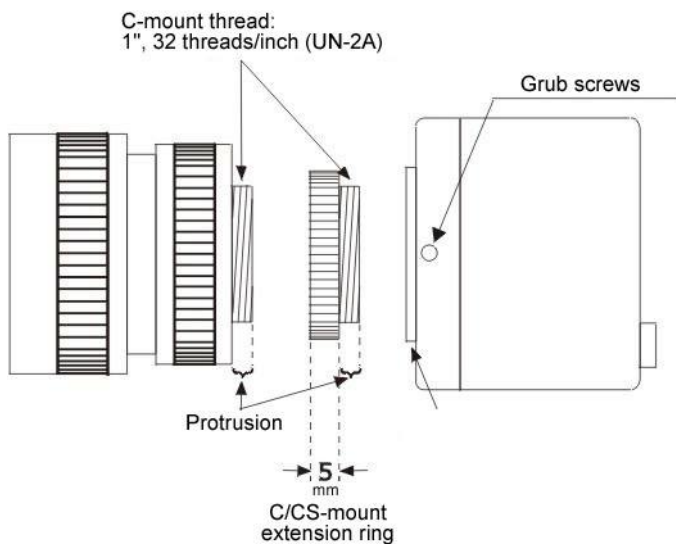

Figure 14: Lens Assembly (C-Mount)

The C/CS-Mount ring influences the so-called „flange focal distance“. This is the distance between the back of the lens and (the part that is attached to the camera) and the picture plane– in our case the surface of the CCD sensor. The pictures shown in *Figure 15* illustrate the difference.

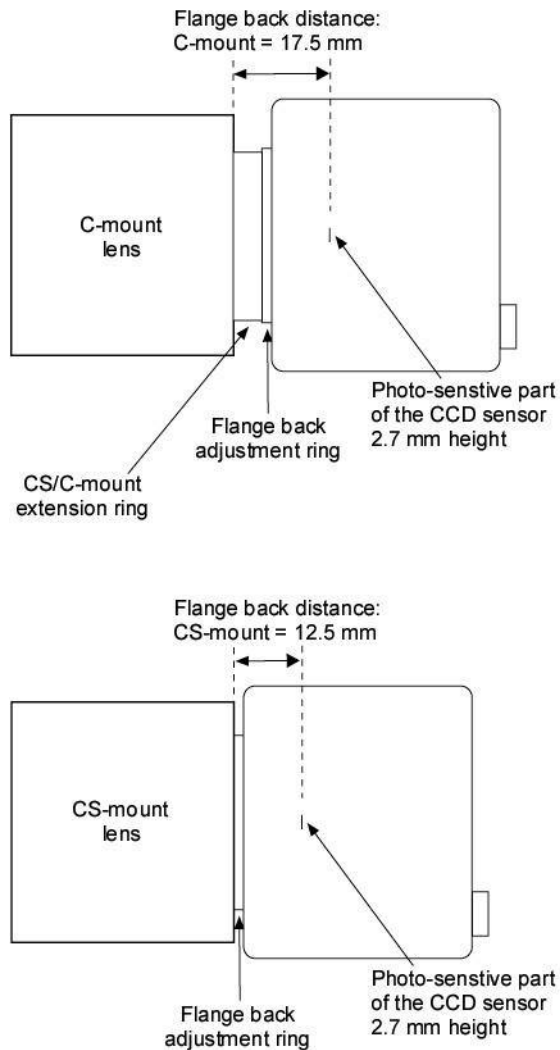

Figure 15: Flange Back Distances and Mounting of C-Mount (Top) / CS-Mount (Bottom) Lenses

In reality the mechanics of the lens and the cameras can vary slightly from one model to another, which may also influence the flange focal distance. If, for example, you are not able to set your lens to „infinite focus“, this is a typical sign of an incorrect flange focal distance.

In this case you can solve the problem with the help of the camera's flange focal distance setting ring. As shown in *Figure 14*, this ring is attached with two set-screws.

You can access these screws through two holes on the side and the bottom of the camera housing. After you have loosen the set-screws, you can adjust the camera's flange focal distance setting ring according to your requirements.

Hints:

- Adjustment of the flange focal distance is usually only required if you are having problems with focusing in „infinite“ or with objects close to the lens. Since adjusting the flange focal distance can quickly lead to problems with the imaging system, it should only be done if absolutely necessary!
- If the picture is out of focus in all of the lens ranges, please check to see if you have a C-Mount lens (use adapter ring) or a CS-Mount lens (remove adapter ring).
- It is possible that the lens is not suited for the desired object distance. In this case you will be able to focus on remote objects, but not on close objects. The required minimum distance between the object and the lens is called the *minimum object distance* (M.O.D.) and is provided in the lens data. PHYTEC support will be happy to advise you on the selection of an alternative lens or on the implementation of extension rings, which reduce the M.O.D.

Caution!

Some lenses have very high insertion depth. In these cases the above portioned parts of the lens can damage the Sensor and/or the filter of the same. Please note that when you are using this type of lens your warranty is made void.

2.4 Installation of the Demo Program

Use the PHYTEC demo program to test the functions of the camera. You can find it on the CD enclosed with the camera (SO-221). You can download updates of the demo software on the PHYTEC website.

Caution!

Check first to see if your computer meets the following system requirements for operating the camera:

- USB 2.0 interface
- processor: Pentium IV, 2GHz, 512 MB RAM or higher
- Graphics adaptor with 24 or 32-bit colour depth
- Operating system: Windows XP SP3, VISTA, 7, 8, 10 (32 / 64 Bit)
- DirectX 9.0c or higher

Make sure that your computer meets the hardware requirements and is equipped with this software.

To install the driver software for the USB camera, proceed in the following manner:

Caution!

The DirectX driver must be installed prior to installation of the driver software for the USB camera. Otherwise not all driver functions will be supported and/or the system may crash.

- Connect the camera to your computer. To install the driver the camera must be ready for operation. Follow the instructions in the previous sections for this.
- Insert the CD SO-221 in your computer's CD-ROM drive.
- The CD should start automatically, bringing up the title menu shown in *Figure 16*: Title menu of the 'Vision Tools' CD.
If the CD doesn't start automatically: open the content folder of the CD (from your desktop or using Windows Explorer) and double click on *start.exe*.

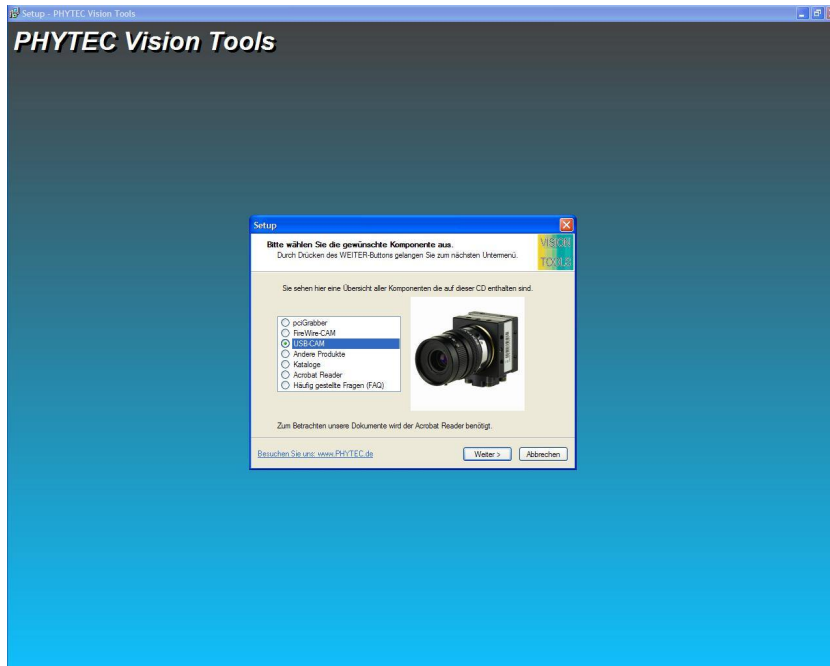

Figure 16: Title Menu of the, Vision Tools' CD

- Click on *USB-CAM*. You will be taken to the installation menu for the PHYTEC USB cameras. Select *PHYTEC DEMO* (Figure 17) and click on *Next*.

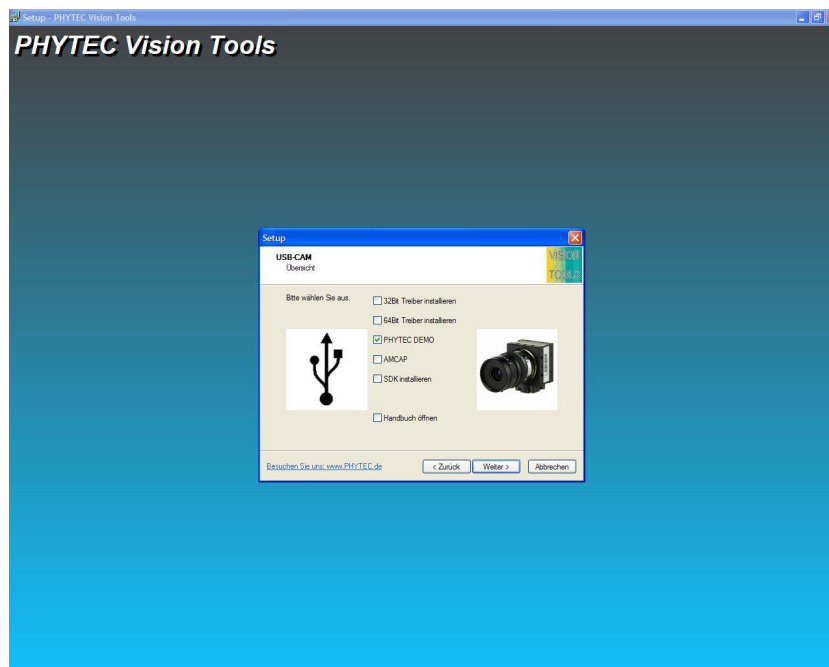

Figure 17: Installation Menu for the USB Cameras

- The demo program's installation program for the USB cameras will appear, *Figure 18*:

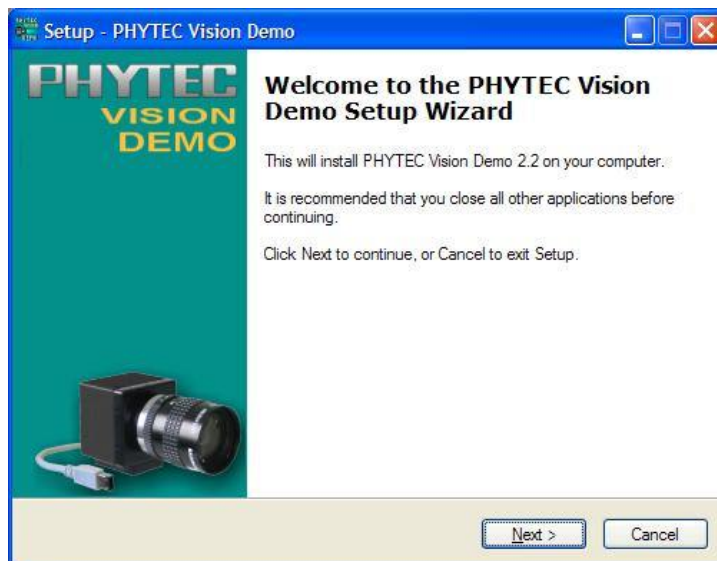

Figure 18: Demo Installation, Step 1

- Click on „Next“.

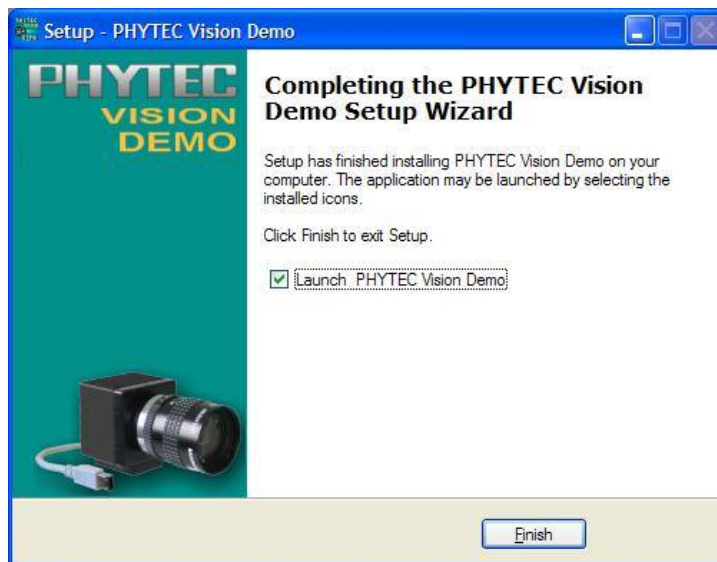

Figure 19: Installation Completed, Step 4

- After successfully completing the installation, finish the procedure with „Finish“, *Figure 19*.

2.5 Starting Up the Camera with the Demo Program

2.5.1 The First Live Image

After you have established the necessary connections, installed the driver and the demo software and mounted a lens following the instructions in the previous sections, you can now start up the camera and display a live image on the screen.

You can also use the program *amcap.exe* by Microsoft™ included on the CD SO-221 for the display of a live image.

To use all of the cameras' features, we nevertheless recommend the PHYTEC Vision Demo program as described in the following.

Start the „PHYTEC Vision Demo“ from the list you chose during the installation.

- The program surface will appear (*Figure 20*).

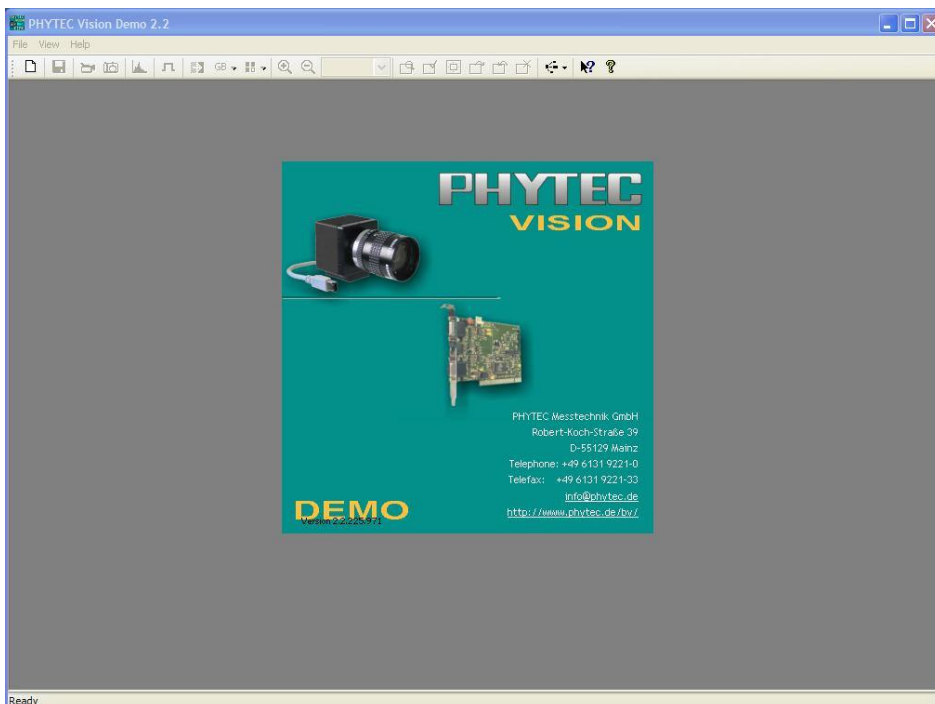

Figure 20: The Program „PHYTEC Vision Demo“

- Choose then the correct image source.

Select therefor in „Select Device“ the desired camera from „USB-CAM-xxx“(Figure 21).

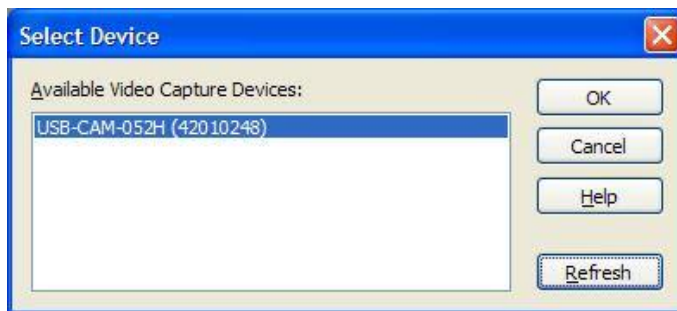

Figure 21: PHYTEC Vision Demo – Select Device

- A live image will appear in the program window (Figure 22).
- In case the live image does not appear, choose the entry „Live“ under „Device“.

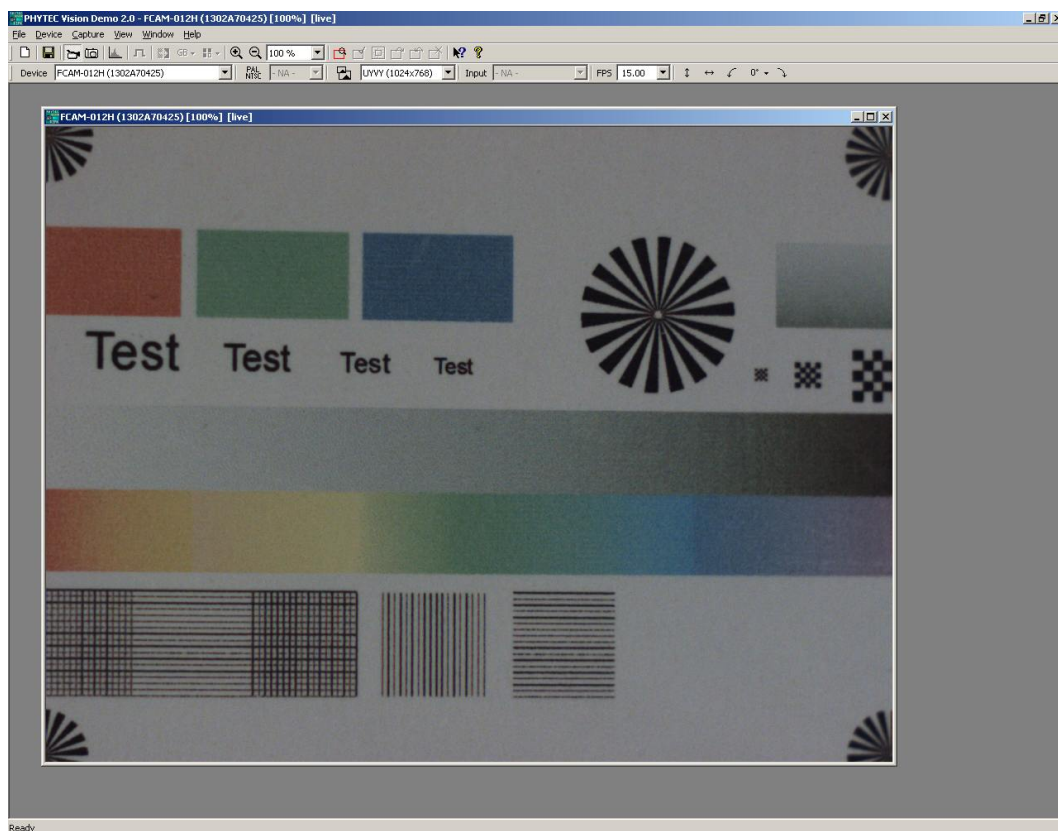

Figure 22: PHYTEC Vision Demo – Live View Function Activated

2.5.2 Select resolution

Die PHYTEC – USB-Cameras can be very flexible adapt to different tasks by adjust the resolution.

Consequently one camera model is used in several applications, which before had several different cameras are selected and stored.

The desired resolution can be easily done by software.

By changing the resolution, other parameters of the camera are changed. For optimum adjustment of the camera, it is therefore useful to identify the best possible resolution.

The following parameters are in this interaction:

- *Resolution*

The image resolution should be set so high that a sufficient representation of image details is guaranteed. To prevent visual effects and problems that may arise from sub-sampling of fine structures, you should choose the native resolution slightly higher than the calculated.

Remember that a too high resolution produces a high amount of data that can adversely affect the performance of the computer and the application software.

- *Frame rate*

The smaller the image resolution is chosen, that so greater the maximum possible refresh rate is. If a fast refresh rate is required (for example, because fast moving objects are to be included), you should set the smallest possible resolution.

Note: The exposure time can be chosen much shorter than the refresh rate. During a short exposure time in objects ensures that no motion blur, high frame rate is advantageous when as many steps in the movement details ("slow motion") and many objects in succession want to record. For the liquid motion perception by the human eye already has a refresh rate of 15 fps (frames per second) is sufficient.

- **Light sensitivity**
 The camera's sensitivity determined together with the lens quality and the aperture set, as long as the image for a given lighting must be illuminated so that it is acceptable visible.
 The higher the light sensitivity, to be shorter can be chosen the exposure time under otherwise identical conditions. Or the other way: Aperture or lighting can be reduced if the light sensitivity is higher.
 Some models of USB-CAMs have the opportunity to reduce the resolution by binning. Binning neighboring pixels edited together into a larger virtual pixels.

As a result, the light sensitivity of the individual pixels are combined. The camera is more light sensitive.
 Use the binning mode, if you need a higher light sensitivity of the camera.

- **Sensor format**
 depending on the method of resolution reduction, changed the virtual sensor format and the actual photosensitive area of the image sensor.
 By reducing the resolution by the formation of a selection window on the sensor (ROI - Region of Interest), decreases the active image area.
 This effect is taken into consideration in the calculation and selection of suitable lens (see Section 3.2).
 The use of binning does not change the sensor format.

The following tables show the parameters for different camera models:

Models	USB-CAM-003H, USB-CAM-103H USB-CAM-004H, USB-CAM-104H			
	Resolution	Format	fps	Sensitivity
resolutions by software	744 x 480	1/3"	60	4,8 V/lux-sec
	640 x 480	1/3,5"	90	4,8 V/lux-sec
	320 x 240	1/7"	150	4,8 V/lux-sec

Figure 23: resolutions W-VGA-Models

Models	USB-CAM-051H, USB-CAM-151H USB-CAM-052H, USB-CAM-152H			
	Resolution	Format	fps	Sensitivity
	Auslesefenster (ROI)			
resolutions by software	2592 x 1944	1/2,5"	6	1,4 V/lux-sec
	2048 x 1536	1/3"	9	1,4 V/lux-sec
	1600 x 1200	1/4"	13	1,4 V/lux-sec
	1280 x 960	1/4,5"	19	1,4 V/lux-sec
	1024 x 768	1/5,5"	27	1,4 V/lux-sec
	640 x 480	1/9"	52	1,4 V/lux-sec
	Binning Mode			
resolutions by software	1280 x 960	1/2,5"	15	5,6V /lux-sec
	640 x 480	1/2,5"	23	22,4 V/lux-sec

Figure 24: resolutions 5 Megapixel-Models

2.5.3 Problem Solving

Check the following points if the live picture is poor or doesn't appear:

- No „Video Device“ is recognized
 - Is the camera connected to the computer correctly?
 - Is the software driver installed?
 - Is DirectX, Version 9.0c or higher installed?
- The picture is black
 - Is the iris of the lens open?
- The picture is only black and white (gray levels)
 - Do you have the color version USB-CAM?
 - Is the software driver installed?
 - Is the correct camera model selected?
 - Was a color format selected with the settings?
 - Is your graphics card configured for more than 256 colors?
 - Is DirectX, Version 8.1 or higher installed?
- The picture quality is poor
 - Is the iris of the lens opened sufficiently?
 - Is the illumination sufficient?
 - Is your graphic card configured for more than 256 colors?

- Try to adapt the camera parameters or set them to their „default“ values (*see next section*)
- The image is not focussed/cannot be focussed
 - Check the lens setting
 - Has the minimum object distance (M.O.D.) been met?
 - Does the extension ring need to be removed/mounted?
 - If necessary adjust the flange focal length (**Caution!**).
- The image display is too slow / flickers
 - the exposure time is set at a higher rate as the display speed (*see next section*)
 - You can set the display speed (*see next section*)
 - It is possible that your computer's processor performance is too low
- The picture flickers under artificial lighting
 - Adjust the picture frequency to the frequency of the artificial lighting. Use either a high exposure time or use frequency-independent lighting.

Note:

- Occurring interference at 30 Hz is not a defect. Conventional TV cameras in Europe always work with the lower image frequency of 25 Hz, to avoid these interferences.
- The exposure time is (largely) independent from the image frequency. Thus the settings do not influence each other.

2.5.4 Adjusting Camera Settings

The USB-CAM series offers a large number of setting options, which can be adjusted via software from the computer.

The setting options are grouped in multiple dialogs (menus).

Depending on the application the call of the dialogs can occur at various locations.

This section provides a brief overview of the setting options and the call of the dialogs in the program PHYTEC-Vision-Demo.

- Setting the Video Format

Setting in the PHYTEC-Vision-Demo:
Device ▶ Settings...

Here you can make basic settings for the image format and color depth.

Furthermore you can see the serial number of the camera and you can also set the picture refresh rate.

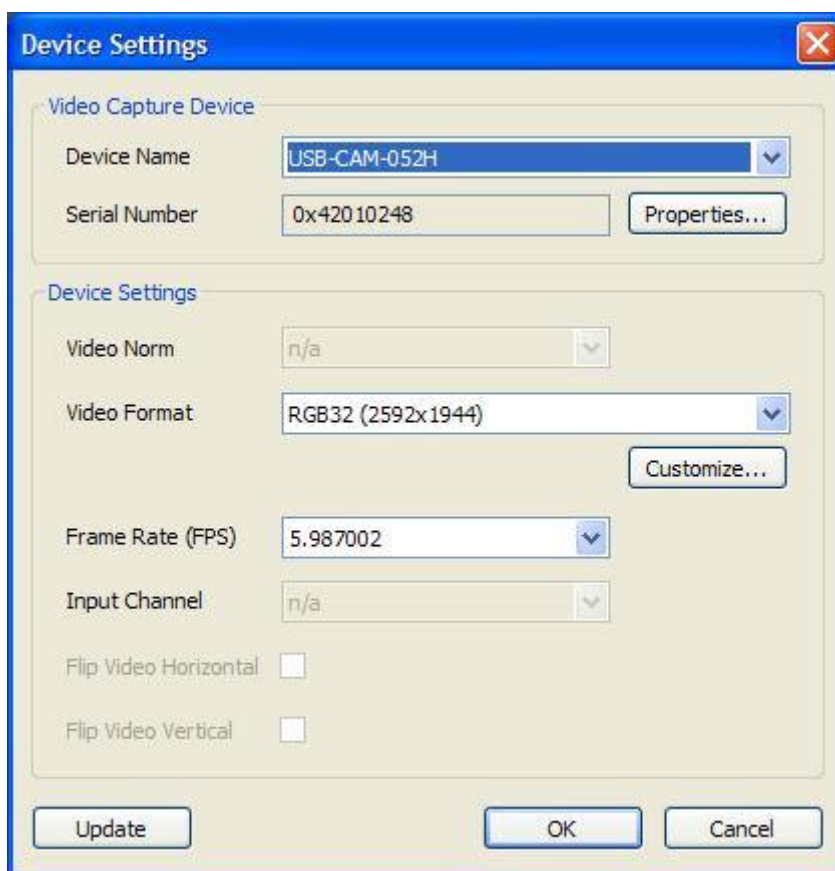

Figure 25: Camera Setting „Device Settings“

Note:

The button „Properties“ will take you to the dialog described in the following.

- Changing the Capture Settings

Settings in the PHYTEC-Vision-Demo:
Device ▶ Properties

This dialog enables you to adjust the image capture precisely to your image capture specifications.

In the camera's default setting all parameters are regulated automatically. In order to make the settings manually remove the „Auto“ check from behind the desired parameter (→) and set the desired value with the sliding control.

Please note that depending on the camera model not all setting options can be selected.

- Properties – Color (Figure 26):

In this dialog you can set the values for hue, saturation and white balance.

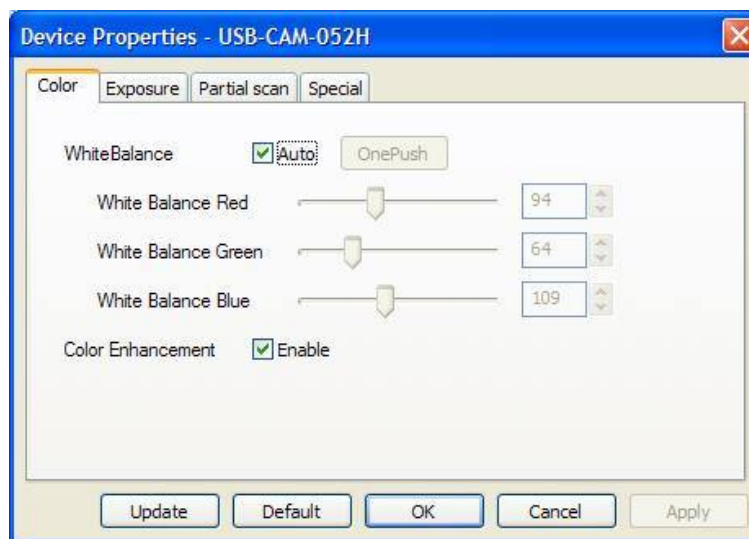

Figure 26: Camera Setting „Properties Color“

- Properties – Exposure (*Figure 27*)

In this dialog you can set the brightness and the gain. Furthermore you can set the reference parameter for the automatic exposure timer. This allows the general lighting impression to be adjusted to the application.

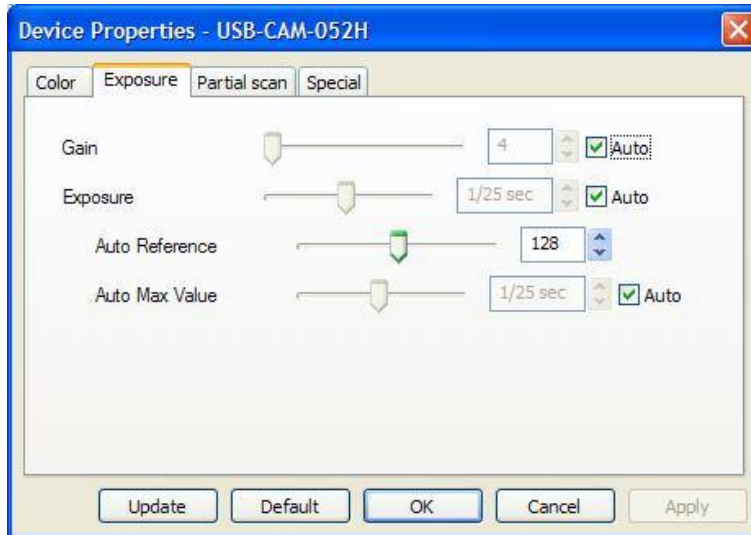

Figure 27: Camera Setting „Properties Exposure“

- Properties – Special (*Figure 28*)

In this dialog you can activate the external trigger. Depending on selection, the camera either is on hold in the trigger mode or behaves as a “free running” camera.

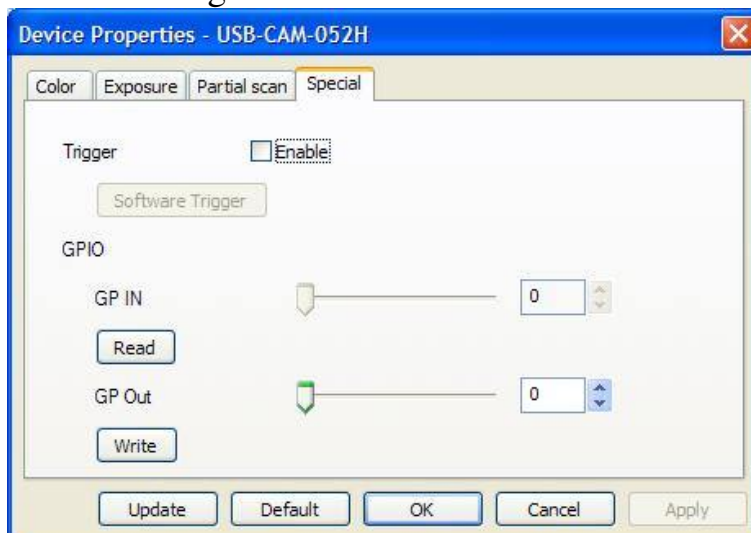

Figure 28: Camera Setting „Properties Special“

The dialog **Special** allows the access to several special parameters of the camera that are usually not disclosed. GPIO and Strobe are at the moment not supported.

- Properties – Partial Scan (Figure 29)

This dialog is only for the USB-CAM-051H, 151H, 052H and 152H are available.

In this dialog you can select the binning. So you can take several pixel together and receiving a higher sensitivity. With the Offset you can individually set the center of the image.

ACHTUNG: ATTENTION: The binning is only available with a resolution of 640x480 or 1280x960. You must first set the right resolution bevor you can use the binning mode.

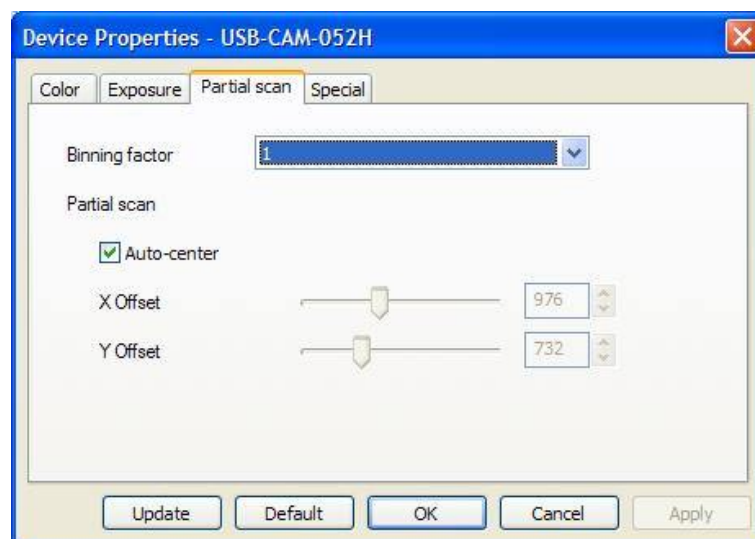

Figure 29: Further: Camera Settings „Partial Scan“

Further on the PHYTEC-Visio-Demo offers a multitude of functionalities that can be adjusted directly in the main window when all the possible toolbars are activated (*Figure 30*).

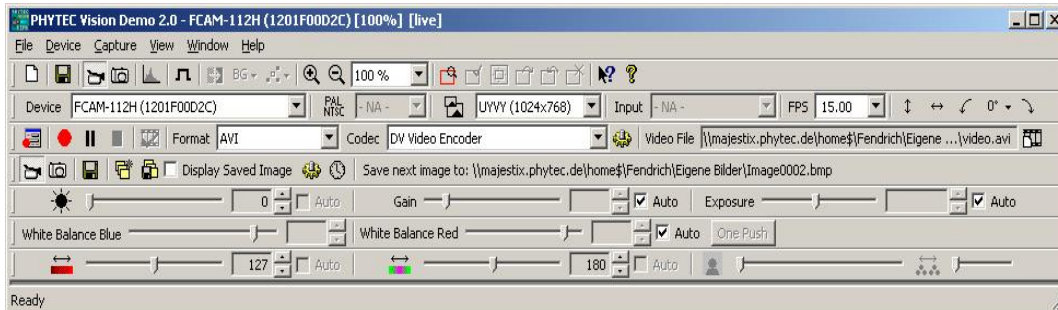

Figure 30: Further possible Settings of the PHYTEC-Vision-Demo

Further functions of the PHYTEC-Vision-Demo:

- Recording an AVI file
- Storing of an individual image (BMP / JPG)
- Recording of an image sequence
- Setting and displaying ROI
- Mirroring and rotating
- Zooming
- Noise reduction
- Histogram display

These functions can be selected either via the respective menu entries or directly by activating the respective toolbar.

3 The Camera in Detail

3.1 Camera Connections

3.1.1 USB Interface

The camera is equipped with an USB 2.0 connector. PHYTEC offers a suitable USB cable. As an alternative you can use other cables, as long as they meet the USB 2.0 standard. *Please refer the section 1.4, “Important Notes “ before proceeding.*

The camera is powered via the USB port.

Make sure that the used USB interface, can provide enough power for the camera. The USB 2.0 interface can be loaded associated with standard loaded up to 500 mA. If you using a USB hub you usually need an external power supply for the hub, otherwise the USB interface can be optionally loaded with about 100 mA.

3.1.2 External Triggering, FCAM-111H /112H Only

Some Models of the USB-CAM series provides an external trigger input and a digital output. These cameras have an additional 4-pin connector (Hirose: HR10A-7R-4P) (*see Figure 31*) for feeding the external trigger signal and using the digital output.

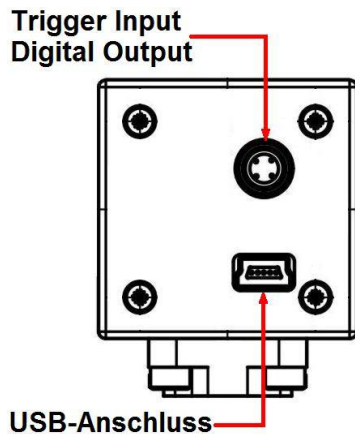
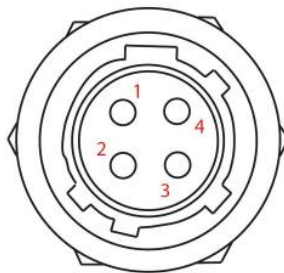

Figure 31: Connections USB-CAM

The *Trigger_in* – Input is optically isolated and can be triggered with a voltage of 3.3 V to 12 V.

The cameras can be operated free-running or triggered.



Pin	Signal	I/O	Description	Min	Max
1	GND	-	Ground	-	-
2	Output	Out	Output (Open Drain)	-	24V
3	Trigger_In(-)	In	Trigger Input GND	-	-
4	Trigger_In(+)	In	Trigger Input Signal	3,3V	12V

Figure 32: Trigger-Connector

3.1.2.1 Trigger functions

free running operation:

Depending on the selected image repeat rate and exposure time, the cameras continuously deliver an image data stream just like a standard camera. The signal behavior at the external trigger entry is insignificant. The exposure time can be adjusted via software from 100 μ s up to 30 s.

triggered operation:

As long as there is no flank change from Low to High, the camera will not deliver image data.

The exposure of the sensor will start with a maximum delay of 100 μs after the Low-High change-over at the external trigger entry.

The exposure time can be adjusted via software.

If a repeated trigger impulse is triggered during an exposure (transmission), undefined conditions may happen during the picture recording.

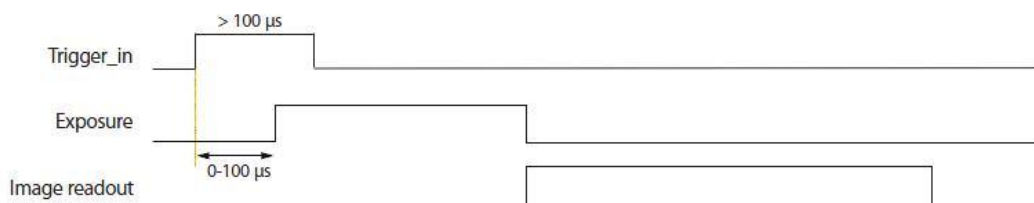

Figure 33: Waveform Trigger

To test the trigger functions, please use the PHYTEC demo program (section 2.4).

3.1.2.2 Digital Output

To control external components with the camera (for example a light) some models of the USB-CAM series has a digital switching output.

Inside the camera is thereby a MOSFET transistor. This transistor is software controlled. It can connect the output to Ground or it is closed (isolating).

The digital output must be wired as shown in *Figure 34*.

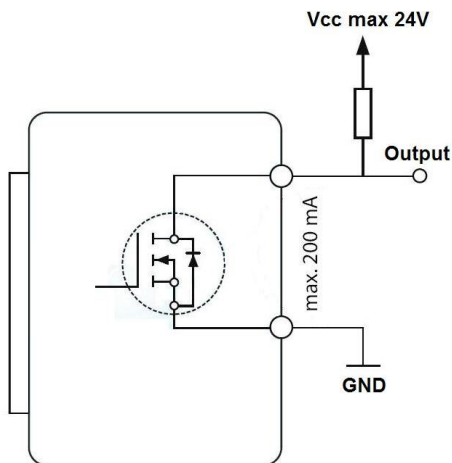

Figure 34: Digital Output

Note:

The following points must be considered:

- The maximum current that can flow through the transistor is 200mA.
- The maximum voltage at the output (for example over a Pull-Up-Resistor) is 24 volt in relation to ground.

Sample code for addressing the digital output:

```
private VCDSimpleProperty VCDProp;

private void Form1_Load(object sender, EventArgs e)
{
    icImagingControll.Device = "DEVICE NAME";
    // Abfrage der Kamera Einstellungen.
    VCDProp=
    CDSimpleModule.GetSimplePropertyContainer(icImagingControll.VCDPropertyItems);
    // Den neuen Werte für den Ausgang setzen.
    VCDProp.RangeValue[VCDIDs.VCDElement_GPIOWrite] = 0;
    // Auf den Ausgang schreiben.
    VCDProp.OnePush(VCDIDs.VCDElement_GPIOWrite);
}
```

3.2 Connecting the Lens

The camera supports lenses with C-Mount or CS-Mount connectors. Refer to section 2.3 for instructions on connecting the lens.

Hints for Selecting the Lens

In order to take full advantage of the quality and the features of the camera, it is important that you select a lens that is optimized to your application. In the following section we have provided some helpful hints on how to proceed in the selection of a suitable lens.

- **Focal Length**

With the focal length you determine the visible screen window, or image portion captured by the camera.

The focal length depends on the size of the sensor-chip, the distance from the object and the focal length of the lens being used.

The screen window should be optimized so that the object being captured is always fully visible on the screen, and also so that the amount of unused screen space surrounding the object is minimized. Otherwise the object would be displayed unnecessarily small and the camera's resolution would not be fully utilized.

The sizes of the various sensor are documented in chapter 5.

Note:

When you use a smaller resolution, only a section of the complete image sensor is used. Therefore, for each sub-resolution, a different focal length is specified.

When using a USB-CAM-051H, 151H, 052H or 152H, it is possible to use the binning method. It combines pixels, so that the whole sensor space can be used. The focal length remains the same.

The following formula can be used to calculate the required focal length f from the desired frame width B and the distance between the object and the lens (L) (all values in millimeters). The s parameters are the width of virtual sensor at the adjusted resolution:

$$f = \frac{s}{B} \cdot L$$

Approximate values for the sensor width s :

Models: USB-CAM-051H, USB-CAM-151H, USB-CAM-052H, USB-CAM-152H			
Resolution	Sensor format	Sensor height (h)	Sensorbreite (s)
Readout window (ROI)			
2592 x 1944	1/2,5"	4,3mm	5,7mm
2024 x 1536	1/3"	3,4mm	4,5mm
1600 x 1200	1/4"	2,6mm	3,5mm
1280 x 960	1/4,5"	2,1mm	2,8mm
1024 x 768	1/5,5"	1,7mm	2,3mm
640 x 480	1/9"	1,1mm	1,4mm
Binning-Mode			
1280 x 960	1/2,5"	4,3mm	5,7mm
640 x 480	1/2,5"	4,3mm	5,7mm

Figure 35: virtual sensor sizes (5M-pixel models)

Models: USB-CAM-003H, USB-CAM-103H, USB-CAM-004H, USB-CAM-104H			
Resolution	Sensor format	Sensor height (h)	Sensor width (s)
Readout window (ROI)			
744 x 480	1/3"	3,4mm	4,5mm
640 x 480	1/3,5"	2,9mm	3,8mm
320 x 240	1/7"	1,4mm	1,9mm

Figure 36: virtual sensor size at different resolutions

You can calculate the focal length for the width or height. Round the resulting value up to the next available focal distance. This will give you a slightly bigger screen window than necessary but it ensures that the entire object will be captured on the screen.

The image height H is calculated from the image width B based on the following relationship:

$$H = \frac{h}{s} \cdot B$$

Please note that wide angle lenses will produce some edge distortion, which can have a detrimental effect during image capture or analysis. In this case try increasing the distance to the object and set a larger focal length.

Reference points for selecting focal length (by 1/3" – format):

Focal Length	Lens Type
< 8 mm	Wide Angle
8 ... 16 mm	Normal Range
> 16 mm	Telephoto Lens

A selection of standard lens focal lengths can be found in our catalog and on our web site. Please ask us about other available focal lengths.

- **Resolution**

How good will the picture resolution be for a given focal length? This depends on the picture size (size of the screen window) and the number of pixels the sensor has.

The number of pixels of your relevant camera are listed in Chapter 1.3.

You can now begin to determine the special resolution by dividing the picture width in mm by the number of horizontal pixels (1024) (corresponding vertically).

Example:

You have a screen window that is 100 mm x 75 mm.

The maximum resolution that can be achieved is

100 mm : 1024 = 0.09765 mm horizontal resp.

75 mm : 768 = 0.09756 mm vertical

The actual resolution that can be achieved is usually smaller, since the quality of the lens and some technical characteristics of the camera (e.g. the band width of the analog amplifier) also play a role. With color cameras in single chip technology, you must also consider that the pixels have color filters, which also reduce the resolution (primarily the local resolution of the color information). The actual resolution of a system (lens – camera) can be determined automatically and is given in terms of so-called *TV-lines*. This is the number of perpendicular black/white lines per screen window that can be differentiated.

- **Minimum Object Distance**

The minimum object distance (M.O.D.) determines the minimum distance between the object and the lens at which the picture can be rendered in focus.

The M.O.D. value is given in the lens data.

An input M.O.D. = 0.3 m means that the object has to be at least 30 cm from the lens.

Often the camera has to be brought closer to the object than the M.O.D. will allow for technical reasons. In this case you can use an extension ring. The extension ring is inserted between the camera and the lens and reduces the M.O.D. value. Since it is difficult to calculate the required length of the extension ring, extension ring sets are available (PHYTEC order number AZ005), that can be used to achieve the required value in application.

- **Aperture**

A lens with a manually adjustable aperture (iris) offers two advantages:

1. The depth of field can be adjusted. By closing the aperture the distance range in which objects are shown in focus is increased. This is of particular importance if the object distance is very small. However the amount of light allowed through by the lens is reduced which means that exposure times will increase and/or the picture will be noisy.

2. The amount of light allowed through the lens can be controlled. This makes sense primarily in applications where there is a lot of light, which could result in overexposure or blooming. In some cases a fixed exposure time may be desired for an application. In this case you can enter the exposure time manually (in the camera dialog) and set the aperture so that the image is properly lit. In normal cases the aperture should only be closed as much as necessary to prevent noise in the picture.

In industrial applications it usually makes sense to be able to lock the selected aperture setting. For this purpose some lenses are equipped with fixing screws.

3.3 Mechanical Attachment

The camera is equipped with a mounting plate with three threaded screw holes (*Figure 37*). The middle hole has a 1/4" – photo thread. This enables the camera to be attached to all standard tripods. The two outer holes have a metric M6 threads. They can be used to attach the camera to a device or in a system without requiring special screws.

Please note that the maximum screw depth is 8 mm.

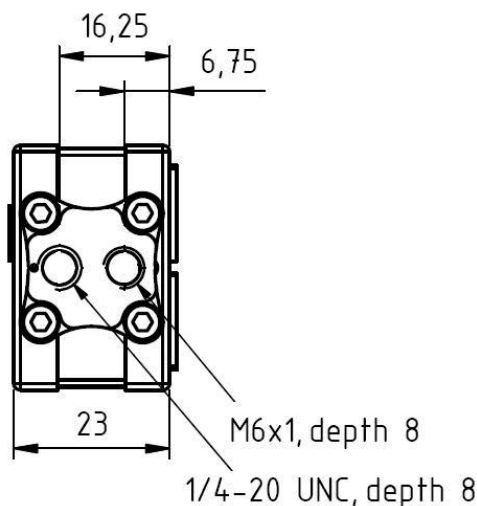

Figure 37: Mounting Plate

The mounting plate is attached to the camera with four screws (*Figure 38*). It can be connected to any side of the camera (*Figure 39*). The attachment is therefore very flexible and can be easily adapted to a given application.

Note:

If necessary, you can also attach the camera directly (without using the mounting plate) on your body, by using the M3 thread in the camera body.

Pay attention to the proper insertion depth of the screws in order not to damage the camera.



Figure 38: Attachment of the Mounting Plate



Figure 39: Mounting Options of the USB-CAM

3.4 How to Maximize Image Quality

„Image Quality“ is always a relative term. However, the definition of quality really depends on the requirements of the application in question.

3.4.1 Lens

The video lens has a significant influence on the picture quality. Refer to *section 3.4.1* for selection of an appropriate lens. In any case you should use a high quality lens. PHYTEC offers high-quality lenses from Pentax. If you have a special requirement profile we recommend lenses from Schneider Kreuznach. We will be happy to advise you on the selection of an appropriate lens.

3.4.2 Lighting

With image processing applications the selection of the right lighting plays a major role.

Ideally the lighting will illuminate the object evenly and with high contrast. Undesired structures (shadow, and overexposed areas) should therefore occur as little as possible in the picture.

Correct lighting can drastically reduce processing times in many applications. For industrial image processing a series of special lighting techniques have been developed that can increase picture display quality in various applications.

In this section we briefly describe a few lighting procedures.

- **reflected-light method**

The reflected light method is one of the most commonly used lighting methods.

In this method a light source (e.g. a standard lamp or a special ring light, *see 6*) is pointed at the object from above.

This lighting technique is used if structures need to be recognizable on the object, such as print, dirt, color (in this case a color-stable lighting is recommended) or mounted parts (attendance monitor or position monitor). There are different variations of this method.

Problems that may occur with this procedure are uneven lighting, reflection (particularly on shiny surfaces) and shadows.



Figure 40: PHYTEC Ring Light Order No.: VZ-001-x, VZ-002-x

- **Diffuse Lighting**

With diffuse lighting no direct light rays hit the viewed object. This reduces problems with reflections and overexposed areas.

The Ring Light (*Figure 40*) can generate diffuse lighting if a corresponding filter ring is attached, thereby solving this problem.

For especially critical applications, such as highly reflective surfaces, special shapes are available that shine the light on the object indirectly over a dome shaped lighting bell.

- **Light-Field or Dark-Field Lighting**

These two methods differ from one another considerably in terms of the camera position in relation to the object. The position of the lighting source in relation to the object remains the same.

The light field lighting leaves the ranges of interest dark (e.g. a drill hole in a workpiece). The dark field lighting functions in the opposite manner (7).

The type of lighting should be selected based on the object surface. If necessary tests should be performed with both variants to determine which method displays the structures of interest the best.

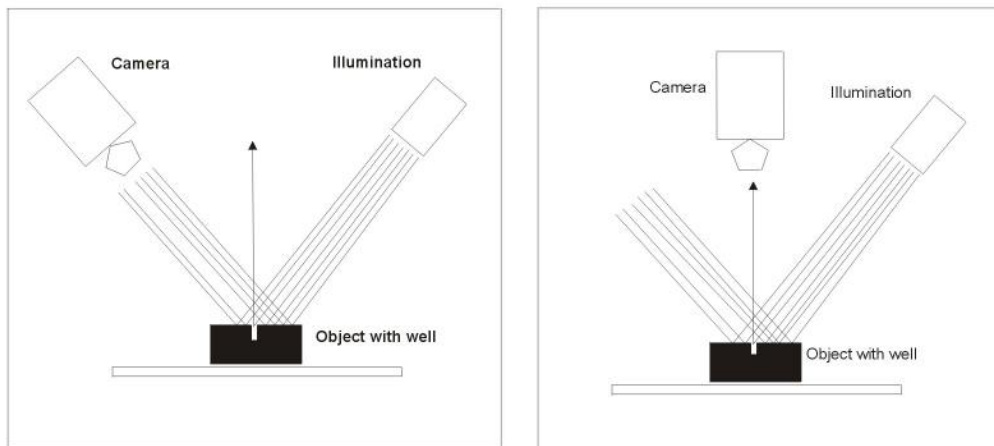

Figure 41: Light-Field- (Left) and Dark-Field-Lighting (Right)

- **Shadow projection**

If object areas and their background are similar in terms of their gray value, the object border can be difficult to discern (contrast problems). If the background isn't too dark, you can measure the object's cast shadow instead of the object edge (8).

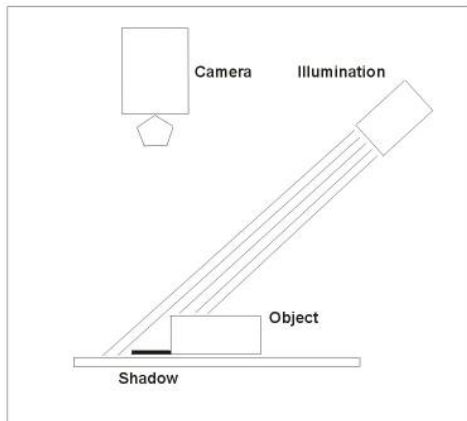

Figure 42: *The Shadow Projection*

- **Structured Light**

In place of the homogenous light described up to this point it is also possible to use a special structured light. This structured light makes it possible to measure the height of an object with a light band or crosshairs (e.g. from a laser). This is an expansion of the shadow projection.

The light line (band) is projected at a known angle α toward the object. The camera is positioned perpendicular to the object. The picture therefore contains two parallel lines, that are a distance d from one another. This distance can be easily measured by the image processing software and converted to height h using the angle α (9).

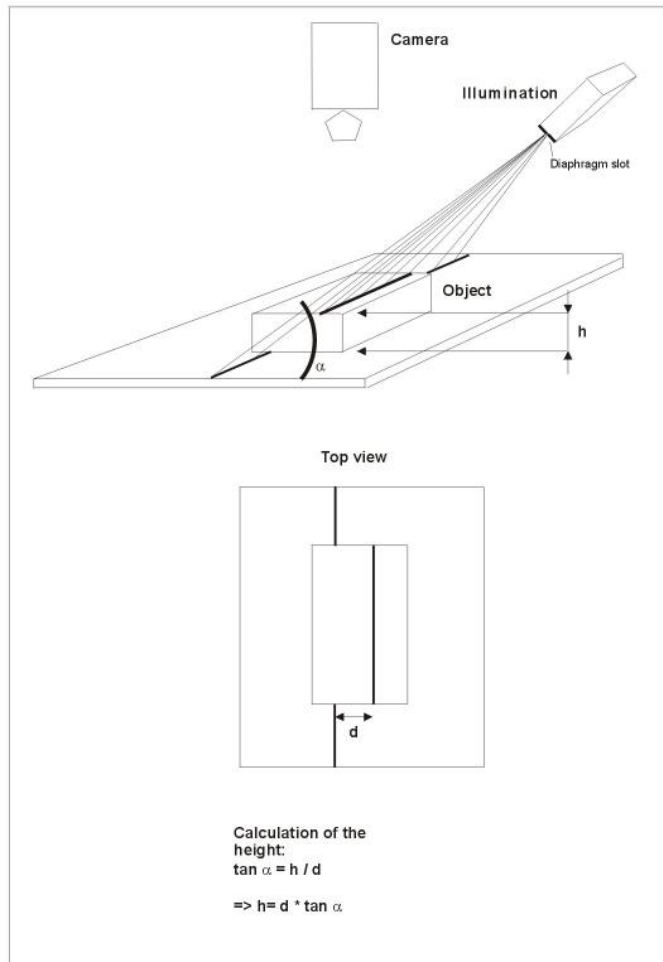

Figure 43: The Structured Light

- **Silhouette Projection**

This method is very useful if you are only interested in the outline of a flat object (e.g. for measurement purposes).

It generates high contrast pictures and is not dependent on the surface of the object.

With the silhouette projection the object is placed before a luminescent plate. It is a diffuse lighting surface that lights the object from below. The camera is pointed at the object from the front, i.e. toward the light source (*Figure 44*).

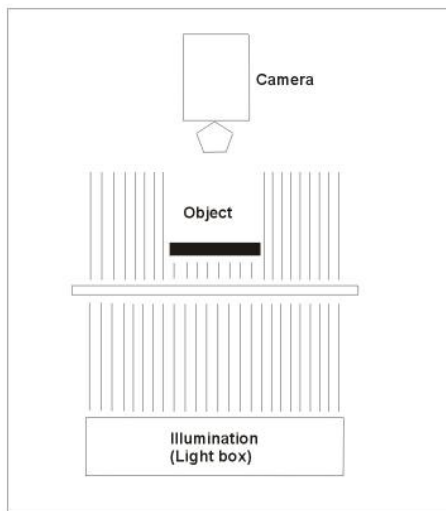

Figure 44: The Silhouette Projection

The result is a grayscale image. The bright pixels are the background, the dark pixels are the object.

- **Transmitted Light Method**

The transmitted-light-method (transillumination) can be very useful with transparent objects like glass. The transillumination makes the inner structures visible (*Figure 45*).

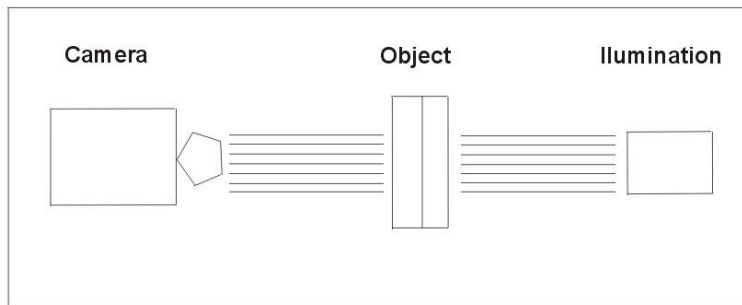

Figure 45: Transillumination

It is possible, for example, to depict the steel wire inside a security glass or the liquid level within a bottle. X-ray images in medical technology are also an example of transillumination.

3.4.3 Camera Setup

The USB-CAM offers a wide range of setting options that enable it to be optimally adapted to the picture requirements.

The individual parameters are listed in *section 0*.

In the following paragraphs the settings used for typical automation and visualization applications are described.

With visualization applications the focus of optimization is primarily the picture as it is seen by the viewer (e.g. remote monitoring, security applications). Automation usually requires constant environmental conditions set according to the given task. The general visual impression is therefore usually a secondary consideration. Instead it is more important that the recognizable features for the subsequent image processing are easily and reliably discernable.

Of course in practice applications there may be instances where a mixture of both requirement profiles is needed.

3.4.3.1 Setting for Visualization with Stable Lighting

Under the assumption that there are stable lighting conditions we recommend the following settings (*see Windows dialogs in section 2.5.4*):

Shutter and Gain: Keep Gain as low as possible and Shutter as high as possible, since Gain not only amplifies the picture signal but also amplifies image noise.

High Shutter values (longer exposure times) can also lead to motion blur. Determine through calculation or experimentation the highest reasonable value and set the *Gain* accordingly, so that the picture brightness is optimized. If necessary adjust the lens aperture to improve the image.

Brightness: Keep the Brightness setting as low as possible. This guarantees the highest gray value dynamic.

Sharpness: Adjust the sharpness of the picture according to the visual impression that it makes. Be aware that too high of a Sharpness setting will also show noise more clearly and may have an unnatural effect on the image. Before adjusting the Sharpness setting, be sure that focus and aperture (= depth of field) settings on the lens are optimized.

Gamma: If you are displaying the pictures on a tube monitor, Gamma should be active. For most other cases Gamma should be shut off. Select the setting according to the visual impression you desire.

Saturation: For a „realistic“ image, in most cases it is recommended that the color saturation adjustment is deactivated. Otherwise a value between 50 and 80 will usually deliver the best results.

White Balance: Use the switch **One Push White Balance** to get a base value. With some slight adjustments afterwards you should easily be able to find the optimal setting.

In most cases the automatic white balance („Auto“) does an adequate job.

3.4.3.2 Visualization Applications with Variable Lighting

If you have to work with changing lighting, you cannot avoid setting some parameters automatically:

Shutter and **Gain** usually have to be operated automatically. In this case the dialog **Auto Exposure** offers the following two parameters that you can use to influence the behavior of the Shutter/Gain regulation.

Exposure Reference: The presetting of this reference value for the automatic lighting is 30. Do not change this value by more than 10. Otherwise it could result in instabilities.

Backlight Correction: If this parameter is set to **OFF**, then the automatic exposure control measures the brightness value of the entire image. If the lighting conditions between the various image portions are considerably different, then you can compensate for this effect with another method of measurement.

This enables you to limit the measuring range to the relevant picture area.

Brightness: Try to avoid using the automatic setting. It is better to keep this value as low as possible. This guarantees the highest gray value dynamic.

Sharpness: Adjust the sharpness to achieve the desired picture effect. As described in the previous section, the proper lens and its correct connection can also be decisive for picture sharpness.

Gamma: If you display the image on a tube monitor then Gamma should be active. For most other cases Gamma should be shut off. Select the setting that gives you the best image in your opinion.

Saturation: For a „realistic“ picture, the deactivation of the color saturation setting is recommend.

Otherwise values between 50 and 80 should deliver the best results.

White Balance: Variable lighting doesn't only result in changes in brightness but also results in spectral variation (changes in color tone). Since the human eye is capable of adapting to these types of variations, we rarely notice even relatively major color variations in light in the course of a day. The camera can also adapt to color variations with the help of the Automatic White Balance.

If only the brightness values change (e.g. if an artificial light source is obscured), then the White Balance can be set manually. By clicking on the switch **One Push White Balance** you will establish a base setting. If necessary you can make slight adjustments afterwards to achieve the optimal setting.

3.4.3.3 Setting for Automated Applications

Automated applications usually require stable lighting and therefore manual parameter settings (*see dialog in section 2.5.4*).

Shutter and Gain: Keep the Gain setting as low as possible and the Shutter setting as high as possible, since Gain not only amplifies the image signal but also the noise.

High Shutter values (longer exposure times) can result in motion blur. Determine through calculation or experimentation the highest sensible value and then set the Gain to achieve the optimal picture brightness. If necessary adjust the lens aperture to improve the picture.

Brightness: Keep the brightness as low as possible. This guarantees the highest gray value dynamic.

Sharpness: Adjust the image sharpness to the level you desire. In automated applications you should try to set the sharpness to the lowest possible value to avoid noise.

Before adjusting the sharpness setting, be sure that the focus and aperture (sharpness depth) settings on the lens are optimized. Since the sharpness function cannot compensate for a low quality lens, you should be sure to use a lens that is suitable for your application.

Gamma: With some automated applications a linear brightness characteristic may be desired. In this case the Gamma correction should be deactivated.

Usually the Gamma correction should be set so that the picture output is optimized for the application in question.

Therefore with applications that involve object recognition it makes sense to work with the Gamma correction switched on.

4 The Software Concept

One of the most interesting properties of the PHYTEC USB-CAM in terms of software is that it can run with standardized interfaces.

This makes the USB-CAM compatible to the existing Windows driver models. The standard is named DirectShow. Together with DirectShow is a VCD (Video Capture Device) provided.

Detailed information about programming or drivers, see the CD SO-221. After installation of the SDK detailed information available.

4.1 Layers Standards of the USB-CAM Series

Hardware / Protocol

At the hardware layer the standard USB 2.0 is used. Since USB 2.0 defines a data bus certain protocols are required that establish the data exchange between the devices.

With **DirectShow** (part of the Windows SDK) the PHYTEC cameras use a protocol that defines the transmission of uncompressed image data streams as well as the camera parameter settings (e.g. exposure time).

Driver

The protocol is realized on the processor end with the help of a WDM Stream Class driver. WDM stands for „Windows Driver Model“. For mice, keyboards, drives etc. this is standard for a long time. For automated image processing, practical application with support of the USB interface with Windows 2000 or better or DirectX 8 is recommended.

Software Interface

Application software should ideally access the operating system functions and not the hardware itself. Windows offers **DirectX** for image and audio processing. Since the PHYTEC USB-CAM only delivers image data streams, only the portion **DirectShow** is required. DirectShow automatically recognizes the WDM Stream Class driver.

Therefore when using the USB-CAM no additional software is required (excluding the actual application software).

Consequence for the Application Software

- a) If you want to use a ready-made application software, it must be compatible with DirectX (nearly all multimedia products fulfill this requirement).
- b) If you plan on creating your own application software and already have experience programming with DirectX, you can access the PHYTEC USB-CAM WDM driver directly with DirectX. The corresponding programming description is available in the DirectX-SDK from Microsoft. The functions made available by the PHYTEC USB-CAM are described in *section 0*, „“.
- c) If instead you are accustomed to programming frame grabbers (such as the PHYTEC *pciGrabber-4plus*), then the enormous complexity of DirectX is a hurdle that shouldn't be underestimated. Therefore PHYTEC offers a *DirectX-Wrapper* in the **USB-CAM-SDK** which enables easy access to all of the USB-CAM's functions without requiring that the programmer become familiar with the complexities of DirectX.

The SDK includes the connections to various programming interfaces:

- **.NET Components:** for MS Visual Basic .NET and C# .NET
- **ActiveX Control:** for Microsoft Visual Basic 2005 and 2008
- **C++ Class Library:** Microsoft Visual C++ 7.1, 8 and 9

Note:

The USB-SDK is included with the camera package. *You will find it on the „Vision Tools“-CD SO-221.*

You can install it in the CD's USB dialog (*see Figure 9*). For each of these interfaces the SDK makes all required binaries, Headers and Libraries available, including an extensive help menu as well as example projects and demo programs with source code.

The WDM-IAT reduces the complexity of DirectX and makes a logically simple interface available to the programmer.

4.2 Accessing the Camera Driver

Section 4.1 describes the standard layer in terms of the PHYTEC USB-CAM series.

A programmer sees these cameras at the layer of a WDM Stream Class driver. The communication between this type of driver and an application software is defined by the standard called DirectX / DirectShow.

There are three typical ways of accessing a WDM Stream Class driver.

- Programmers who have experience using DirectX can access these drives directly using DirectX.
- Programmers who are not experienced with DirectX can access the driver with the help of the PHYTEC USB-SDKs. The SDK allows easy access from standard Windows programming environments. In terms of software the camera behaves similarly to a standard camera-framegrabber unit. The USB-SDK with the WDM IAT is included with the PHYTEC USB-CAM series. It can be found on the CD SO-221 along with the detailed descriptions of the functions.
- If you would rather avoid programming entirely, you can use the Filter Graph Editor to parameter WDM Steam Class drivers.

4.3 Working with the Filter Graph Editor

The following sections are a brief introduction to the Filter Graph Editor.

With the Filter Graph Editor you can graphically program and test (multimedia-) applications completely or partially.

The functions shown as „DirectShow Filters“ are available to you for this purpose.

4.3.1 How to Get the Filter Graph Editor

The Filter Graph Editor (also called „graphedit“ or „*graphedt.exe*“) is a component of Microsoft’s DDK, that can be downloaded for free from Microsoft.

It is also part of Microsoft’s DirectX SDK, which is available at Microsoft.

Please note that Microsoft does not include the Filter Graph Editor source code or permit redistribution.

4.3.2 Working with the Filter Graph Editor

The Filter Graph Editor is a limited tool. It consists only of the executable program *graphedt.exe* and is therefore easy to locate in the DDK/SDK-Kit. No special installation is required. *graphedt.exe* can be started easily from any folder.

A detailed description of the Filter Graph Editor is available in program’s help function.

4.3.3 How the Camera Appears in the Filter Graph Editor

In the „Graph“ menu select „Insert Filters...“. You will be shown a list of *Filters*, that are available in the operating system.

The camera's WDM Stream Class driver is also considered a filter of this type and is located in the folder „Video Capture Sources“.

The filter parameters (i.e. the camera settings) can be modified by right-clicking on the name of the filter in question (Name of your camera). By selecting „Filter Properties...“ you will be taken to the setting dialog shown in *section 2.5*.

Please note that the camera parameters are not stored in the camera but rather in the registry of the computer that the camera is connected to.

5 Technical Data

Resolution	744 x 480 / 640 x 480 / 320 x 240			
Model	USB-CAM-003H USB-CAM-103H		USB-CAM-004H USB-CAM-104H	
color / monochrom	monochrom		color	
Sensor Format	1/3"			
Image Sensor	Aptina MT9V024, CMOS			
Pixel Size	6 µm x 6 µm			
Color format	Y8		RGB32, RGGB (Raw)	
Lens Holder	C / CS - Mount			
fps	60 fps to 150 fps			
Dynamic Range	8 bit			
Shutter	Global			
Light sensitivity	4,8 V/lux-sec			
Interface	USB 2.0 High Speed			
Exposure time	1/10.000 s to 1/4 s			
Gain	0 dB to 18 dB			
White Balance	-		-6 dB bis +6 dB	
Power supply	4,5 V bis 5,5V DC			
Power Consumption	Circa 250 mA bei 5V			
Feature (optional)	-	ext. Trigger, Digital- Output	-	ext. Trigger, Digital-Output
Temperature range	-5°C bis +45°C			
Dimensions (B x L x H)	36 mm x 36 mm x 25 mm			
Fixing	1/4" and M6x8 on all sides			
Weight	70 g			
Connection	USB Mini-B			
Feature- Connection	-	Hirose HR10A- 7R-4P	-	Hirose HR10A-7R-4P
Order number	AK087	AK089	AK088	AK090

Resolution	2592 x 1944 (5 MPix), 2048 x 1536 (3,1MPix), 1600 x 1200 (2MPix), 1280 x 960 (1,2MPix) 1024 x 768 (0,8MPix), 640 x 480 (VGA)			
Model	USB-CAM-051H	USB-CAM-151H	USB-CAM-052H	USB-CAM-152H
color / monochrom	monochrom		color	
Sensor Format	1/2,5"			
Image Sensor	Aptina MT9P031, CMOS			
Pixel Size	2,2 µm x 2,2 µm			
Color format	Y8		RGB32, RGGB (Raw)	
Lens Holder	C / CS – Mount			
fps	6 fps to 52 fps			
Dynamic Range	8 bit			
Shutter	Rolling			
Light sensitivity	1,4 V/lux-sec			
Interface	USB 2.0 High Speed			
Exposure time	1/10.000 s to 30 s			
Gain	0 dB to 18 dB			
White Balance	-		-6 dB bis +6 dB	
Power supply	4,5 V bis 5,5V DC			
Power Consumption	Circa 250 mA bei 5V			
Feature (optional)	-	ext. Trigger, Digital-Output	-	ext. Trigger, Digital-Output
Temperature range	-5°C bis +45°C			
Dimensions (B x L x H)	36 mm x 36 mm x 25 mm			
Fixing	1/4" and M6x8 on all sides			
Weight	70 g			
Connection	USB Mini-B			
Feature- Connection	-	Hirose HR10A-7R-4P	-	Hirose HR10A-7R-4P
Order number	AK091	AK093	AK092	AK094

5.1 frame rates and sensitivity

The maximum refresh rate and the sensitivity of the cameras depend on the set resolution of the particular camera model:

Models	USB-CAM-003H, USB-CAM-103H USB-CAM-004H, USB-CAM-104H			
	Resolution	Format	fps	Sensitivity
Resolutions by software	744 x 480	1/3"	60	4,8 V/lux-sec
	640 x 480	1/3,5"	90	4,8 V/lux-sec
	320 x 240	1/7"	150	4,8 V/lux-sec

Models	USB-CAM-051H, USB-CAM-151H USB-CAM-052H, USB-CAM-152H			
	Resolution	Format	fps	Sensitivity
	Readout window (ROI)			
Resolutions by software	2592 x 1944	1/2,5"	6	1,4 V/lux-sec
	2048 x 1536	1/3"	9	1,4 V/lux-sec
	1600 x 1200	1/4"	13	1,4 V/lux-sec
	1280 x 960	1/4,5"	19	1,4 V/lux-sec
	1024 x 768	1/5,5"	27	1,4 V/lux-sec
	640 x 480	1/9"	52	1,4 V/lux-sec
	Binning Mode			
Resolutions by software	1280 x 960	1/2,5"	15	5,6V /lux-sec
	640 x 480	1/2,5"	23	22,4 V/lux-sec

6 Dimensions

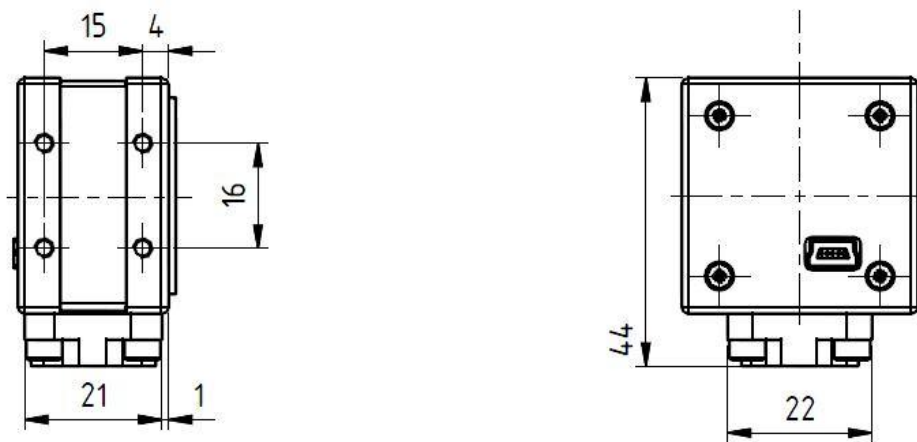
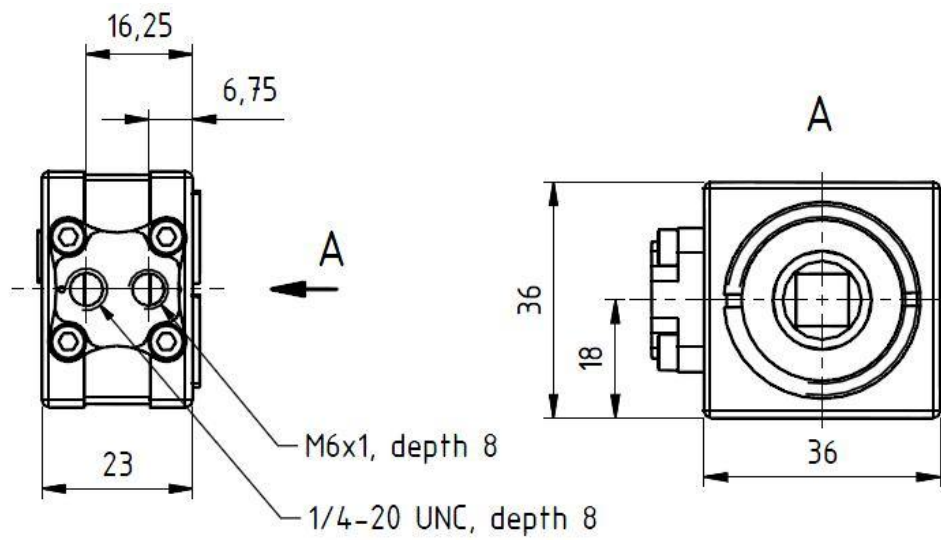

Dimensions: mm
Tolerances: DIN ISO 2768m

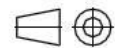
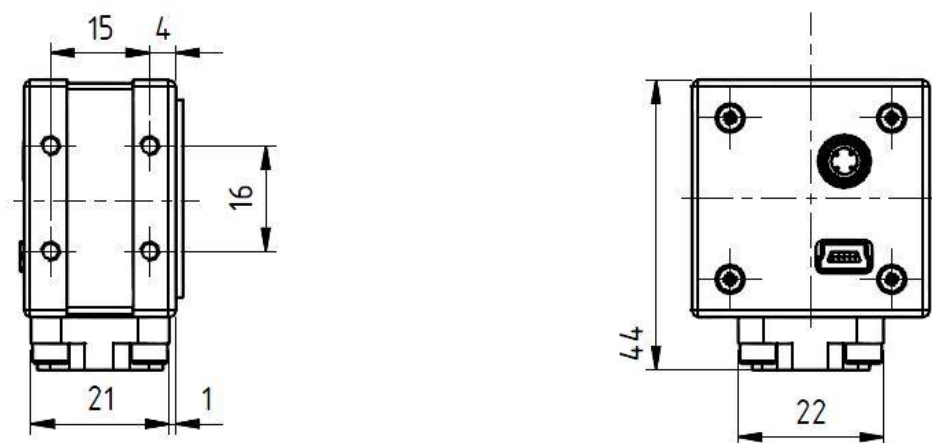
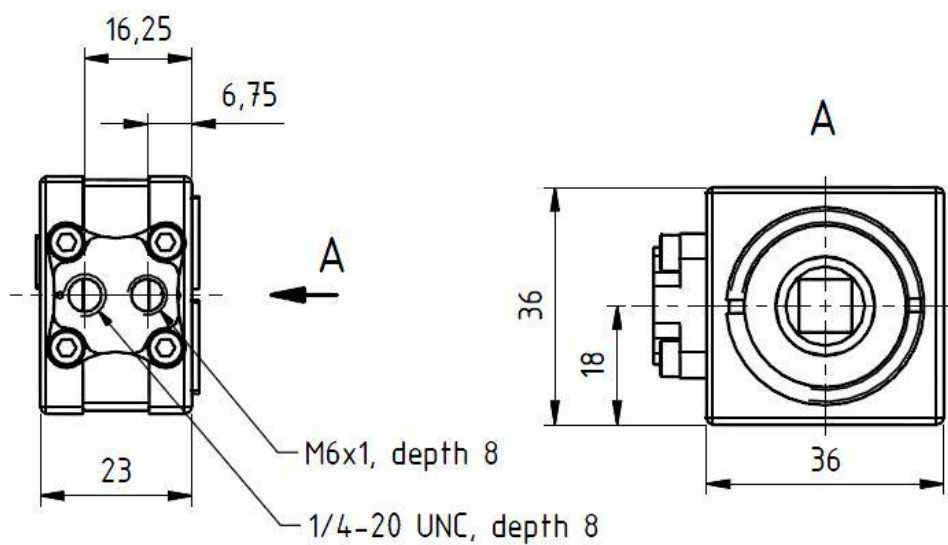

Figure 46: Dimensions without trigger



Dimensions: mm
Tolerances: DIN ISO 2768m

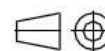

Figure 47: Dimensions with trigger

Dokument: USB-CAM-003H / 103H / 004H / 104H / 051 / 151 / 052 / 152

Dokument Number: L-740e_1, January 2016

How would you improve this manual?

Did you find any mistakes in this manual?

Page

Submitted by:

Customer number: _____

Name: _____

Company: _____

Address: _____

Return to:

PHYTEC Technologie Holding AG

Postfach 100403

D-55135 Mainz, Germany

Fax : +49 (6131) 9221-33

Published by

PHYTEC